

CB200 Conventional Control Panel Installation and Commissioning Manual

Contents

1. Introduction	1
2. Cabinet Installation	4
3. Panel Check.....	7
4. Panel Configuration.....	9
5. Commissioning.....	10
6. Technical Specifications	16
7. Additional Available Documentation.....	17
8. ACCESS CODE Functions	18

1. Introduction

Thank you for purchasing the CB200 conventional control panel. The CB200 range of panels are manufactured to the requirements of BS5839 part 4 1988. The CB200 will provide the user with many years of reliable service.

NOTE: It is important to read this manual fully before commencing installation.

USER CONTROLS ACCESS CODE:

5 1 4

ENGINEER'S ACCESS CODE:

5 3 2 4

SEE SECTION 8 FOR DETAILS

1.1 CB200 - A Guided Tour

1.1.1 Exploded View and Mechanical Data/Text Identification

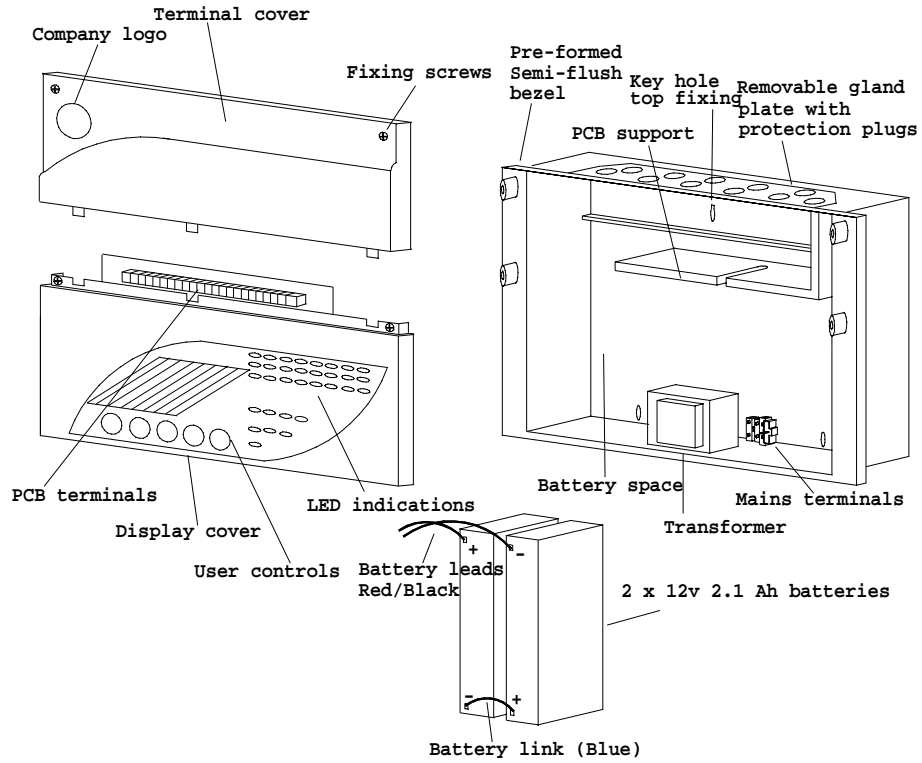

1.1.2 Panel Display and Explanatory Notes (8 zone illustrated)

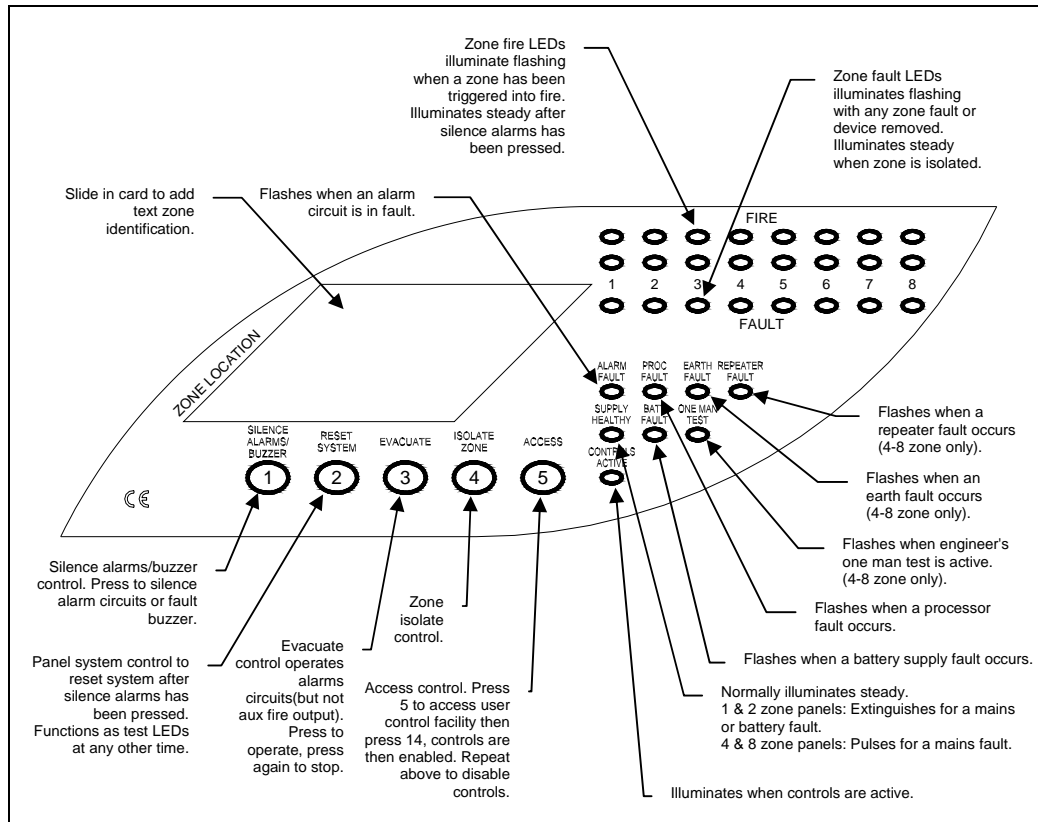

1.1.3 Typical Terminal Wiring Schematic (8 zone illustrated)

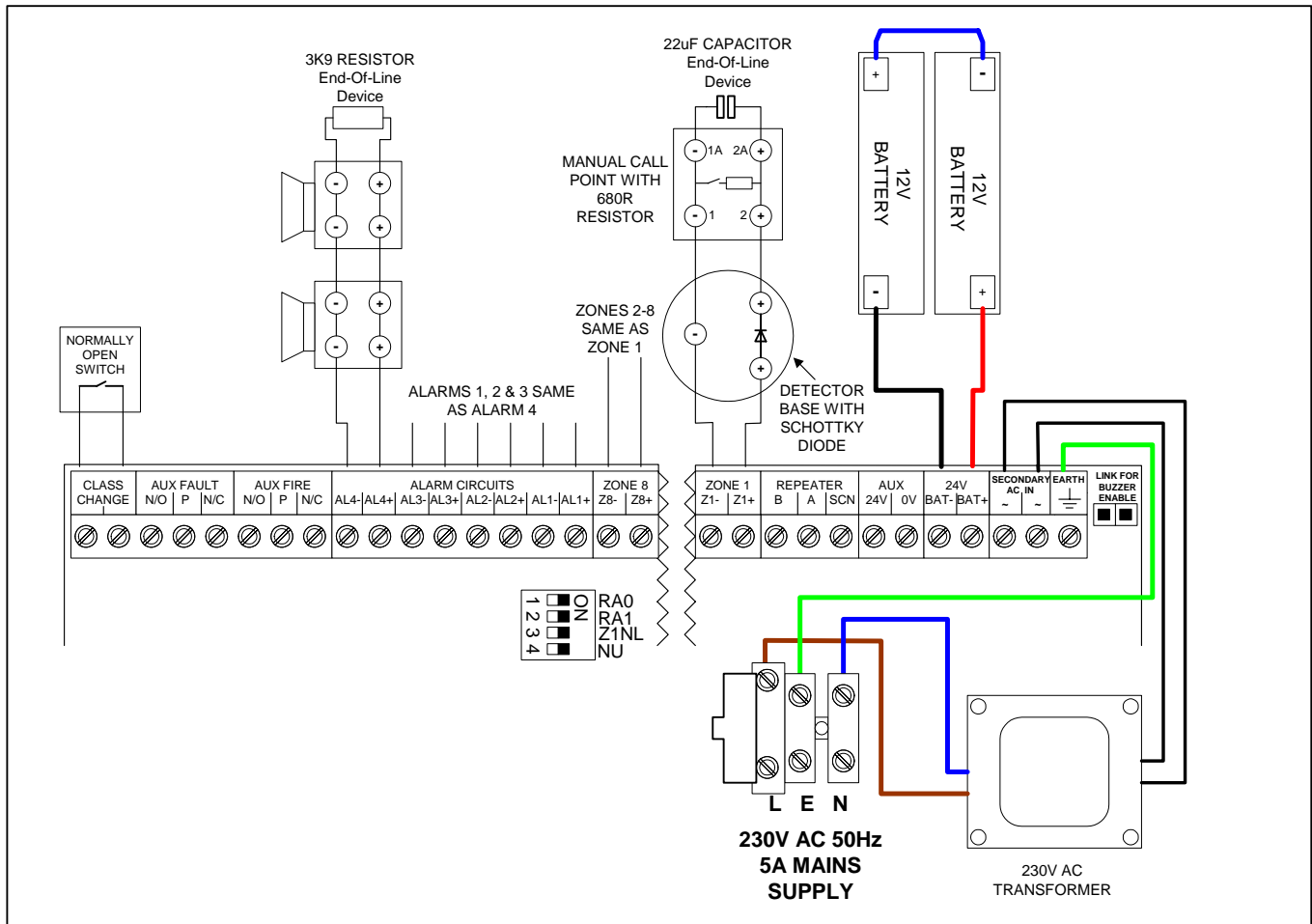

Note: This is a schematic representation only and not a PCB layout drawing.

2. Cabinet Installation

WARNING: Read this section completely before commencing installation.



Prior to commencing installation of the control panel, ensure that adequate precautions are taken to prevent damage to the sensitive electronic components on the control board due to electrostatic discharge. You should discharge any static electricity you may have accumulated by touching a convenient earthed object such as an unpainted copper radiator pipe. You should repeat the process at regular intervals during the installation process, especially if you are required to walk over carpets.

The panel must be located in a clean, dry position, which is not subject to shock or vibration and at least 2 metres away from pager systems or any other radio transmitting equipment. The operating temperature range is 0°C to 40°C; maximum humidity is 95%.

IMPORTANT NOTES ON BATTERIES:



DANGER: Batteries are electrically live at all times, take great care never to short circuit the battery terminals.



WARNING: Batteries are often heavy; take great care when lifting and transporting batteries. For weights above 24 kilos, lifting aids should be used.



DANGER: Do NOT attempt to remove the battery lid or tamper with the internal workings of the battery. Electrolyte is a highly corrosive substance, and presents significant danger to yourself and to anything else it touches. In case of accidental skin or eye contact, flush the affected area with plenty of clean, fresh water and seek immediate medical attention.

Valve Regulated Lead Acid (VRLA) batteries are “low maintenance”, requiring no electrolyte top-up or measurement of specific gravity.



WARNING: Only clean the battery case with a cloth that has been soaked or dampened with distilled water. Do not use organic solvents (such as petrol, paint thinner, benzene or mineral spirits) or other materials that can substantially weaken the case. Do not use a dry cloth as this will generate static electricity, which in turn may lead to an explosion.



WARNING: Avoid operating temperatures outside the range of -15°C/5°F to +50°C/122°F for float/standby applications.

The recommended normal operating temperature is 20°C.

HIGH TEMPERATURE will reduce battery service life. In extreme cases this can cause Thermal Runaway, resulting in high oxygen/hydrogen gas production and battery swelling. Batteries are irrecoverable from this condition and should be replaced.

LOW TEMPERATURE will prolong battery life but reduce output capacity.



DANGER: Do not incinerate batteries. If placed in a fire, the batteries may rupture, with the potential to release hazardous gases and electrolyte. VRLA batteries contain substances harmful to the environment.



DANGER
Harmful fumes

Exhausted batteries must be recycled. Return them to the battery manufacturer or take them to your Council waste disposal site for appropriate disposal.

ELECTRICAL SAFETY:

The volt-free relay contacts provided within the panel must not be used to directly switch any voltage that exceeds 50VAC or 75VDC. (Please also refer to relay rating data).

This equipment requires a 230V AC supply. All installation work should be carried out in accordance with the recommendations of BS5839 Part 1 and the current edition of the IEE regulations by suitably qualified and trained personnel.



THIS PANEL MUST BE EARTHED

Installation Sequence

1. Unpack the control panel and locate the small plastic bag containing the following installation spares:
 - a) End of line capacitors (22 μ F 35/40 volts – for Zone circuits only)
 - b) End of line resistors (3k9 Ohms – for alarm circuits only)
 - c) Spare mains fuse
 - d) A set of battery leads (RED - positive, Black – negative, Blue - jumper lead)
2. Remove the terminal cover and display cover by means of the fixing screws. Place both covers carefully to one side (ideally inside the original packing box). Note that the mains transformer leads and Earth lead will need to be disconnected from the control board in order to remove the control board.
3. Offer the empty enclosure to the wall, mark and fix using fixings appropriate for the weight.
4. Connect 230V AC mains to the mains terminal block provided inside the enclosure, ensuring that the mains supply is isolated at the source. See diagram below for cable routing recommendations. The cable must be secured via the Cable Tie.

The cable must be protected by a 5A fuse at the source.

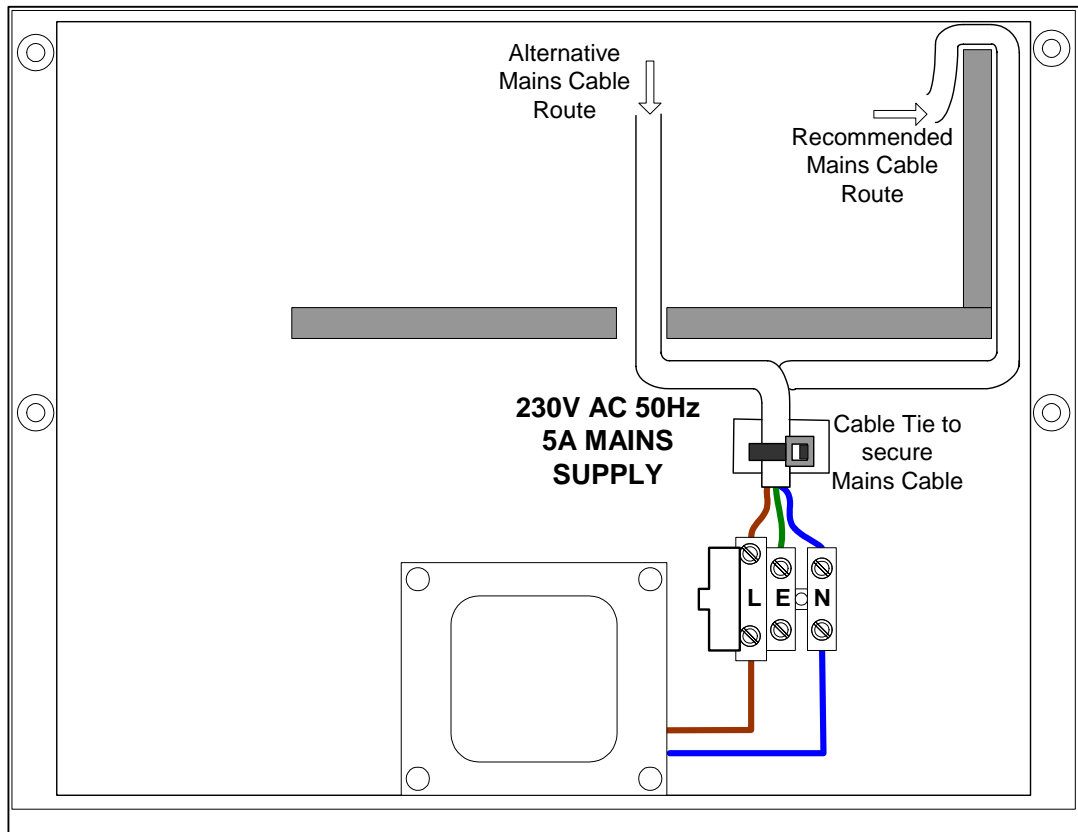

NOTE 1 – MAINS ISOLATION:

An appropriate lockable double pole disconnect device shall be provided as part of the building installation.

NOTE 2 – MAINS CABLES:

Use only mains cable compliant to BS6004, BS6500, or equivalent, within the following limits:

	Cable Diameter	Conductor Diameter
Minimum Dimensions	4.0mm	1.0mm (0.8mm ²)
Maximum Dimensions	8.0mm	2.25mm (4.0mm ²)

5. Gland the installation wiring into the enclosure using the cable entry holes provided in the removable gland plate. Leave the plastic protection plugs in any unused holes.
6. Fill in the Zone Identification label and insert it into the display cover from the rear of the display cover.
7. Fit batteries into the space provided. Only connect the blue battery link, **do not** connect the red and black battery leads to the batteries at this time.
8. Re-attach the display cover, ensuring that the low voltage secondary AC leads from the transformer and the earth lead from the mains terminal block pass through the cable channel to the upper section of the enclosure.
9. Connect the transformer secondary leads to the “AC IN” terminals. Connect the earth lead from the mains terminal block to “EARTH” (4 & 8 zone panels only). Ensure the earth lead to the gland plate is connected properly.

3. Panel Check

1. Ensure the mains supply has been inspected and tested in line with BS5839 Part 1 and the current IEE regulations. Ensure that the system is correctly earthed.
2. Leave all resistors and zone capacitors in place and switch on the 230 volts AC mains only. The control panel should react as follows:
 - i) The GREEN “Supply Healthy” LED illuminates
 - ii) The GREEN “Controls Active” LED illuminates
3. No other indications should be present at this time. If there are, identify the fault and rectify it by checking that the end of line devices are connected correctly in the terminals on each zone, alarm circuit and battery terminals. Also check that all DIL switches on the control board are in the OFF position.
4. Remove the resistor from the battery terminals on the control panel. The panel should react as follows:
 - i) On 1 & 2 zone panels, the AMBER “General Fault” LED illuminates; on 4 & 8 zone panels, the AMBER “Batt Fault” LED illuminates
 - ii) On 1 & 2 zone panels, the GREEN “Supply Healthy LED is extinguished.
 - iii) The control panel internal buzzer sounds
 - iv) The Fault Relay output operates
5. Connect the Red battery lead to the BATT+ terminal on the panel and connect the Black battery lead to the BATT- terminal on the panel. Connect the other end of the Red lead to the Red (+) terminal on one battery and connect the other end of the Black lead to the Black (-) terminal on the other battery. The control panel should react as follows:
 - i) The buzzer silences and the fault indications are cleared

- ii) The GREEN "Supply Healthy" LED re-illuminates (1 & 2 zone panels)
6. Press and hold the "Test Lamps/System Reset" button on the display and check that the control panel reacts as follows:
- i) All LEDs on the display illuminate whilst the switch is operated
 - ii) The internal buzzer sounds
7. Release the Test Lamps/System Reset button and observe that the panel returns to it's previous state.
8. Press the "Evacuate" switch on the display and check that the control panel reacts as follows:
- i) The panel buzzer operates
 - ii) 28V DC can be measured across each of the alarm circuits
 - iii) Press the "Evacuate" switch again to return the panel to normal
9. Switch off the 230V AC supply to the control panel and check that the control panel reacts as follows:
- i) On 1 & 2 zone panels, the "General Fault" LED illuminates and the "Supply Healthy" LED extinguishes; on 4 & 8 zone panels, the "Supply Healthy" LED flashes
 - ii) The internal buzzer in the control panel sounds
 - iii) The Fault Relay output operates
 - iv) The "Supply Healthy" LED extinguishes

Re-instate the 230V AC supply and check that the panel returns to normal.

10. Check that the zone detection circuits are monitoring the wiring for faults correctly, as follows:
- i) Open circuit (to simulate a break in the circuit wiring) – remove the negative leg of the zone capacitor
 - ii) Short circuit (to simulate a short between cores) – reconnect the negative leg of the capacitor & short circuit the zone terminals

Simulate the faults described above and check that the control panel reacts as follows:

- i) The appropriate AMBER "Zone Fault" LED pulses
 - ii) The internal buzzer on the control panel sounds
 - iii) The fault relay operates
11. Check that the alarm circuits are monitoring the wiring for faults correctly, as follows:
- i) Open circuit - remove end-of-line resistor
 - ii) Short circuit - replace resistor & short circuit the alarm circuit terminals

Simulate the faults described above and check that the control panel reacts as follows:

- i) The "General Fault" LED illuminates (1 & 2 zone panels only)
- ii) The "Alarm Fault" LED illuminates (all panels)
- iii) The internal buzzer in the control panel sounds
- iv) The fault relay operates

4. Panel Configuration

WARNING: *The link labelled “Link for Buzzer Enable”, located at the top of the PCB, is a non-monitored buzzer disable/enable facility. Its purpose is to disable the buzzer should the engineer find this necessary during commissioning. **DO NOT** remove this link unless there are exceptional circumstances, and **ALWAYS** check that it is in place before closing the cover.*

4.1 One Man Test: 1 & 2 Zone Panels

This Engineer’s control is located on the top right hand corner of the PCB. The functions of the switch are described below.

One-man Test mode:- press and hold for more than 5 seconds. Check that the control panel reacts as follows:

- i) “General Fault” LED flashes
- ii) The fault buzzer sounds
- iii) “Supply OK” LED flashes

Press the one-man test switch briefly to return panel to normal mode.

NOTE: The control panel will automatically de-select the one-man test after 10 minutes of non-operation.

4.2 One Man Test 4 & 8 Zone Panels

1. Enter the engineer’s access code (5324), the “Controls Active” LED will flash. To exit engineer’s mode, press 5. If no controls are operated for 10 seconds the panel will automatically exit engineer’s mode.
2. One-man Test - with engineer’s controls active, press 1 to enable One-man Test. Check that the control panel reacts as follows:
 - i) “One-Man Test” LED flashes
 - ii) The fault buzzer sounds
3. Press 1 again to clear.

NOTE: *The control panel will automatically de-select the one-man test after 10 minutes of inactivity.*

4.3 Earth Fault Enable/Disable (4 & 8 zone panels only)

With engineer’s controls active, press **2** to enable/disable earth fault monitoring. When in engineer’s mode, the “Earth Fault” LED will illuminate when earth fault monitoring is enabled.

4.4 Processor Fault Indication

1 & 2 Zone Panels:

If the processor stops, the “Proc. Fault” LED will illuminate. Press the “Processor. Reset” button (top right hand corner of the PCB) to re-start the processor. To clear the processor fault LED, press the “Proc. Fault Reset” button adjacent to the “Processor Reset button (make sure controls are enabled).

4 & 8 Zone Panels:

If the processor stops, the processor will be re-started automatically and the "Proc. Fault" LED will pulse. To clear the LED indication, first enter the engineer's access code (**5324**) and then press **4**.

4.5 Zone 1 Non-latch Configuration

Zone 1 can be configured to operate in a non-latching fire indication mode by setting the "Z1NL" DIL switch to the ON position.

In this mode, if a fire condition occurs on zone 1 the panel will indicate the fire condition and operate the alarms. The auxiliary fire relay contacts will **not** be operated. When the fire condition is cleared from zone 1, the zone 1 fire indication is cleared and, as long as no other zones are in fire, the alarms are also cleared. If any other zone is in a fire condition the panel will remain in the fire condition until manually reset.

The zone 1 non-latch enable switch is identified in section 1.1.3.

4.6 Zone Isolation

Zone Isolation can only be performed at the control panel. Enable the controls then follow the instructions below. Isolated zones are indicated by a steady amber fault LED.

1 & 2 zone panels:

- (i) Press "Zone Isolate" to isolate zone 1
- (ii) Press & hold "Zone Isolate" for more than 5 seconds to isolate zone 2

De-isolate the required zones using the same process.

4 & 8 zone panels:

- (i) With controls active, press "ZONE ISOLATE". The Zone 1 Fault LED will pulse rapidly every 2 seconds (flashing cursor mode).
- (ii) Press "ACCESS" (button 5) to move the cursor to the required zone.
- (iii) Press "ZONE ISOLATE" to isolate or de-isolate the required zone.
- (iv) Repeat (ii) and (iii) for any further zones.
- (v) Press "RESET" to clear the flashing cursor mode.

5. Commissioning

5.1 Introduction

The following equipment should be available where possible to minimise the commissioning period:

- i) VHF/UHF 2-Way Portable Radio System (for two engineers)
- ii) Multi-meter capable of measuring voltages and resistances

5.2 Checklist

Before commissioning, the engineer should check the following:

- i) All field wiring has been inspected and tested in accordance with the manufacturer's wiring recommendations, BS5839 part 1 and current IEE wiring regulations.
- ii) All field cables are glanded into the control panel cabinet.
- iii) Detector bases are linked through but detector heads are not fitted. Any devices with electronic components are not fitted. Terminations to devices with electronic components should be linked through to maintain cable continuity.
- iv) Call points are not connected but the cable is linked through to maintain continuity.
- v) No end-of-line devices are fitted (except at the panel terminals).

The following information should be available to the commissioning team:

- (i) Zone detection layout drawings
- (ii) Wiring schematic diagram
- (iii) Installation manuals for all equipment connected to the system

Tracing wiring faults on long circuits that are routed through risers etc. can be difficult without prior knowledge of the wiring route.

It is recommended that the electrical installer is available until basic wiring continuity is proven. A minimum of 2 persons (e.g. engineer & mate) is recommended for efficient commissioning.

5.3 An Overview of the Commissioning Procedure

The approach to be used when commissioning a fire alarm system is to check each circuit and function in turn to ensure correct operation of the entire system. In this way any faults may be located quickly and accurately. The general procedure is as follows:

1. Alarm circuits should be checked first. The operation of each sounder should be checked for correct audibility as specified in BS5839 pt 1, using the "EVACUATE" facility on the control panel.
2. Zone Detection circuits should be commissioned next. The requirement is to verify the correct operation of each device and check for correct indication at the control panel.
3. Finally, any auxiliary circuits should be tested.

WARNING: *Before testing, the engineer must be aware both of the operation of all devices fitted to the auxiliary circuits and of the consequences of their operation.*

5.4 Pre-Commissioning Wiring Check

NOTE: *This pre-commissioning wiring check procedure should be followed in order to test all wiring prior to specific commissioning of any detection, alarm and auxiliary circuits.*

The following assumes that the control panel has been installed in accordance with the installation procedure and is powered with only the "Supply Healthy" and "Controls Active" LEDs illuminated. Do not connect field wiring at this stage.

1. Ensure that no devices are connected to the zone and alarm circuits but the cables are linked through at the device locations to achieve a continuous circuit.
2. Ensure that resistance of all cables to earth and between cores is more than $1M\Omega$. Check the following:
 - i) Positive to earth resistance is greater than $1M\Omega$
 - ii) Negative to earth resistance is greater than $1M\Omega$
 - iii) Positive to negative resistance is greater than $1M\Omega$
 - iv) Connect a wire link as the end-of-line device on each of the zone and alarm circuits. At the panel end, measure the resistance across the positive & negative ends of the cables for each of the circuits; ensuring the value does not exceed 20Ω . Remember to remove the wire links after the tests.
3. Correct polarity throughout all circuits must be maintained. Rectify any faults.
4. All bells, detector heads and call points should now be connected and the correct end-of-line devices fitted. Use the spare end-of-line devices supplied and leave the EOL devices in the panel terminals at this stage. Remember to remove any links fitted to detector bases. Be very careful to maintain correct polarity at each device.

5.5 Alarm Circuits

After completion of the pre-commissioning wiring check, the following procedure should be followed:

1. Remove the resistor from the first alarm circuit terminal and connect the first alarm circuit wiring to the terminals, observing correct polarity. Check that any alarm fault indications clear after a few seconds.
2. Enter the access code to enable the controls and press the "Evacuate" switch. Check that all sounders connected to the alarm circuit operate.
3. Press the "Evacuate" switch again and check that the alarms silence.
4. Repeat steps 1 to 3 for the remaining alarm circuits.

5.6 Zone Circuits

NOTE: Remember to enable the controls using access code 514 before using any of the controls.

1. Remove the capacitor from the zone 1 terminals and connect the cables of the zone 1 circuit to the panel terminals, observing the correct polarity. Check that any zone 1 fault indications clear after a few seconds.
2. Check that the zone detection circuits are monitoring the wiring for faults correctly. To do this the wiring on the zone detection circuits must be placed into the following conditions:
 - i) Open circuit (disconnect the EOL capacitor)
 - ii) Short circuit (short circuit the EOL capacitor)

Return the EOL capacitor to normal and check that the panel returns to normal.

3. Operate the first manual call point (BGU) on the zone and check the following:

- i) The zone 1 fire LEDs pulse
- ii) The internal buzzer sounds
- iii) The alarms sound
- iv) The auxiliary fire relay operates

Reset the break glass unit to its normal condition. Press the "Silence Alarms" button and then the "System Reset" button on the panel's display board and check that the control panel returns to its normal state.

4. Repeat step 3 for all BGUs on the zone.
5. Operate the first detector on the zone and check the following:
 - i) The zone 1 fire LEDs pulse
 - ii) The internal buzzer sounds
 - iii) The alarms sound
 - iv) The auxiliary fire relay operates
 - v) The LED on the detector illuminates

Press the "Silence Alarms" button and then the "System Reset" button on the panel's display board and check that the control panel returns to its normal state.

6. Repeat step 5 for all detectors on the zone.
7. Remove the first detector from zone 1 and observe the following:
 - i) The appropriate amber zone fault LED illuminates
 - ii) The internal buzzer sounds
 - iii) The fault relay operates

Operate a break glass unit between the detector that has been removed and the EOL capacitor. Check that the panel reacts as described above for a fire condition. Refit the detector, reset the BGU, press the "Silence Alarms" button and then the "System Reset" button on the panel's display board and check that the control panel returns to its normal state.

8. Repeat step 7 for all detectors on the zone.
9. Repeat steps 1 to 8, one zone at a time, until all the zones are commissioned.
10. Any faults that are found must be traced and rectified before proceeding.

Repeater 0	Repeater 1	Repeater 2	Repeater 3																																																																																
<table border="1"> <tr><td>1</td><td><input type="checkbox"/></td><td><input type="checkbox"/></td><td><input type="checkbox"/></td><td>RA0</td></tr> <tr><td>2</td><td><input type="checkbox"/></td><td><input type="checkbox"/></td><td><input type="checkbox"/></td><td>RA1</td></tr> <tr><td>3</td><td><input type="checkbox"/></td><td><input type="checkbox"/></td><td><input type="checkbox"/></td><td>Z1NL</td></tr> <tr><td>4</td><td><input type="checkbox"/></td><td><input type="checkbox"/></td><td><input type="checkbox"/></td><td>NU</td></tr> </table>	1	<input type="checkbox"/>	<input type="checkbox"/>	<input type="checkbox"/>	RA0	2	<input type="checkbox"/>	<input type="checkbox"/>	<input type="checkbox"/>	RA1	3	<input type="checkbox"/>	<input type="checkbox"/>	<input type="checkbox"/>	Z1NL	4	<input type="checkbox"/>	<input type="checkbox"/>	<input type="checkbox"/>	NU	<table border="1"> <tr><td>1</td><td><input type="checkbox"/></td><td><input type="checkbox"/></td><td><input type="checkbox"/></td><td>RA0</td></tr> <tr><td>2</td><td><input type="checkbox"/></td><td><input type="checkbox"/></td><td><input type="checkbox"/></td><td>RA1</td></tr> <tr><td>3</td><td><input type="checkbox"/></td><td><input type="checkbox"/></td><td><input type="checkbox"/></td><td>Z1NL</td></tr> <tr><td>4</td><td><input type="checkbox"/></td><td><input type="checkbox"/></td><td><input type="checkbox"/></td><td>NU</td></tr> </table>	1	<input type="checkbox"/>	<input type="checkbox"/>	<input type="checkbox"/>	RA0	2	<input type="checkbox"/>	<input type="checkbox"/>	<input type="checkbox"/>	RA1	3	<input type="checkbox"/>	<input type="checkbox"/>	<input type="checkbox"/>	Z1NL	4	<input type="checkbox"/>	<input type="checkbox"/>	<input type="checkbox"/>	NU	<table border="1"> <tr><td>1</td><td><input type="checkbox"/></td><td><input type="checkbox"/></td><td><input type="checkbox"/></td><td>RA0</td></tr> <tr><td>2</td><td><input type="checkbox"/></td><td><input type="checkbox"/></td><td><input type="checkbox"/></td><td>RA1</td></tr> <tr><td>3</td><td><input type="checkbox"/></td><td><input type="checkbox"/></td><td><input type="checkbox"/></td><td>Z1NL</td></tr> <tr><td>4</td><td><input type="checkbox"/></td><td><input type="checkbox"/></td><td><input type="checkbox"/></td><td>NU</td></tr> </table>	1	<input type="checkbox"/>	<input type="checkbox"/>	<input type="checkbox"/>	RA0	2	<input type="checkbox"/>	<input type="checkbox"/>	<input type="checkbox"/>	RA1	3	<input type="checkbox"/>	<input type="checkbox"/>	<input type="checkbox"/>	Z1NL	4	<input type="checkbox"/>	<input type="checkbox"/>	<input type="checkbox"/>	NU	<table border="1"> <tr><td>1</td><td><input type="checkbox"/></td><td><input type="checkbox"/></td><td><input type="checkbox"/></td><td>RA0</td></tr> <tr><td>2</td><td><input type="checkbox"/></td><td><input type="checkbox"/></td><td><input type="checkbox"/></td><td>RA1</td></tr> <tr><td>3</td><td><input type="checkbox"/></td><td><input type="checkbox"/></td><td><input type="checkbox"/></td><td>Z1NL</td></tr> <tr><td>4</td><td><input type="checkbox"/></td><td><input type="checkbox"/></td><td><input type="checkbox"/></td><td>NU</td></tr> </table>	1	<input type="checkbox"/>	<input type="checkbox"/>	<input type="checkbox"/>	RA0	2	<input type="checkbox"/>	<input type="checkbox"/>	<input type="checkbox"/>	RA1	3	<input type="checkbox"/>	<input type="checkbox"/>	<input type="checkbox"/>	Z1NL	4	<input type="checkbox"/>	<input type="checkbox"/>	<input type="checkbox"/>	NU
1	<input type="checkbox"/>	<input type="checkbox"/>	<input type="checkbox"/>	RA0																																																																															
2	<input type="checkbox"/>	<input type="checkbox"/>	<input type="checkbox"/>	RA1																																																																															
3	<input type="checkbox"/>	<input type="checkbox"/>	<input type="checkbox"/>	Z1NL																																																																															
4	<input type="checkbox"/>	<input type="checkbox"/>	<input type="checkbox"/>	NU																																																																															
1	<input type="checkbox"/>	<input type="checkbox"/>	<input type="checkbox"/>	RA0																																																																															
2	<input type="checkbox"/>	<input type="checkbox"/>	<input type="checkbox"/>	RA1																																																																															
3	<input type="checkbox"/>	<input type="checkbox"/>	<input type="checkbox"/>	Z1NL																																																																															
4	<input type="checkbox"/>	<input type="checkbox"/>	<input type="checkbox"/>	NU																																																																															
1	<input type="checkbox"/>	<input type="checkbox"/>	<input type="checkbox"/>	RA0																																																																															
2	<input type="checkbox"/>	<input type="checkbox"/>	<input type="checkbox"/>	RA1																																																																															
3	<input type="checkbox"/>	<input type="checkbox"/>	<input type="checkbox"/>	Z1NL																																																																															
4	<input type="checkbox"/>	<input type="checkbox"/>	<input type="checkbox"/>	NU																																																																															
1	<input type="checkbox"/>	<input type="checkbox"/>	<input type="checkbox"/>	RA0																																																																															
2	<input type="checkbox"/>	<input type="checkbox"/>	<input type="checkbox"/>	RA1																																																																															
3	<input type="checkbox"/>	<input type="checkbox"/>	<input type="checkbox"/>	Z1NL																																																																															
4	<input type="checkbox"/>	<input type="checkbox"/>	<input type="checkbox"/>	NU																																																																															

4. Power-up the Panel and then the Repeaters. Only the “Supply Healthy” and “Controls Enabled” LEDs should be illuminated on the Panel and Repeaters. Any repeaters with a built-in power supply should have the batteries connected at this time.
5. At Repeater 1, Press the “Evacuate” button. Check that the alarms operate and the internal buzzer operates on all repeaters.
6. Press the “Evacuate” button on the panel. Check that the alarm circuits silence and the internal buzzer silences on all repeaters.
7. Repeat steps 5 and 6 for each repeater.
8. Operate a Manual Call Point on zone 1 and check for correct fire indication at each repeater.
9. Press the “Silence Alarms” button on a repeater and check that the alarms are silenced and the internal buzzer pulses on all repeaters.
10. Press the “Reset” button on a repeater and check that the panel and repeaters return to the quiescent state.
11. Repeat steps 8 to 10 for each zone and ensure “Silence Alarms” and “Reset” operate correctly from each repeater.
12. Set the panel motherboard DIL switches RA0 & RA1 to OFF (No Repeaters). Check that all repeaters indicate a “Comms. Fault”.
13. Set the panel motherboard DIL switches RA0 & RA1 to back their previous settings and check that the repeaters return to normal.
14. Set the first repeater address to 0. Check that the panel indicates a “Repeater fault” and any additional repeaters display a steady “Comms fault” LED.
15. Set the first repeater address back to normal and check that the panel and repeaters return to normal.
16. Repeat steps 14 and 15 for any other connected repeaters.

5.8 Class Change Input Commissioning

1. Connect the class change switch to the class change input on the motherboard.
2. Operate the class change switch and observe:
 - i) The alarms sound
 - ii) The internal buzzer on the panel operates
 - iii) The internal buzzer on repeaters **does not** operate
3. De-activate the class change switch and observe:
 - i) The alarms silence
 - ii) The internal buzzer on the panel silences.

5.9 Auxiliary Circuits

All auxiliary circuits or equipment that is not supplied as a standard part of the fire alarm panel is the responsibility of the installer and must be tested for safe and correct operation by the commissioning engineer.

Note: CB200 1 and 2 zone panels only.

Issue 0 versions of the CB200 1 and 2 zone PCB have the auxiliary fault contacts labelled incorrectly. The normally closed contact is labelled N/O and the normally open contact is labelled N/C.

To identify the issue level of the board, view the rear of the board. This is the opposite side to the controls and indications. The board number and issue level are located on the right side of the board mid-way between the top and bottom edges.

This problem does not affect any of the following:

- **Any other circuit on the CB200 1 and 2 zone panel.**
- **CB200 1 and 2 zone fitted with C1648 issue 1 (and higher) motherboards.**
- **CB200 4 and 8 zone panels.**

6. Technical Specifications

CB200 1-2 zone control panel

Maximum field equipment load:	800mA
Auxiliary 24VDC output	250mA
Mains failed current consumption:	35mA @24VDC
Maximum battery charger output:	500mA @27.5 VDC
Common fire output:	Volt-free contacts - 1A, 30V DC max.
Common fault output:	Volt-free contacts - 1A, 30V DC max.
Alarm circuit output:	2 at 250mA each @28VDC
Battery size:	2 x 12V 2.1AH sealed lead acid
Weight (excluding batteries):	2.3kg

CB200 4 zone control panel

Maximum field equipment load:	800mA
Auxiliary 24VDC output	250mA
Mains failed current consumption:	40mA @24VDC
Integral battery charger output:	500mA @27.5VDC
Common fire relay:	Volt-free contacts - 1A, 30V DC max.
Common fault output:	Volt-free contacts - 1A, 30V DC max.
Alarm circuit output:	4at 500mA each @28VDC
Battery size:	2 x 12V 2.1AH sealed lead acid
Weight (excluding batteries):	2.3kg

CB200 8 zone control panel

Maximum field equipment load:	800mA
Auxiliary 24VDC output	250mA
Mains failed current consumption:	40mA @24VDC
Integral battery charger output:	500mA @27.5VDC
Common fire relay:	Volt-free contacts - 1A, 30V DC max.
Common fault relay:	Volt-free contacts - 1A, 30V DC max.
Alarm circuit output:	4at 500mA each @28VDC
Battery size:	2 x 12V 2.1AH sealed lead acid
Weight (excluding batteries):	2.4kg

CB200 8 zone repeater panel with integral power supply

Auxiliary 24VDC output	250mA
Mains failed current consumption:	40mA @24VDC
Integral battery charger output:	500mA @27.5VDC
Battery size:	2 x 12V 2.1AH sealed lead acid
Weight (excluding batteries):	2.4kg

CB200 8 zone repeater panel powered from panel

Current consumption:	40mA @24VDC
Weight	1.4kg

RS485 Cable Specification

Generic Type:	RS422/RS485 data cable.
Conductors:	Single pair plus screen.
Alpha cable:	3492C, 6222C, 6412 or equivalent
Belden cable:	8102, 8132, 9841 or equivalent

NOTE:

On 4 and 8 zone panels the total available current for field devices is 800mA at 28VDC. This current must be shared between the auxiliary 24VDC supply and the four alarm circuits such that the total current drain across the five circuits does not exceed 800mA.

**WARNING:**

A fuse protects the internal mains transformer on CB200 Panels and Repeaters; always replace this with the correct type and rating:

T1AH 250V (20mm fuse, 1A, HBC, Anti-surge, approved to BS EN 60127 or equivalent.)

7. Additional Available Documentation

Sales Literature
 Application Guide
 Wiring Recommendations
 Fault Finding Guide
 User Instructions
 After-Sales Technical Support Booklet

8. ACCESS CODE Functions

The functions available at the USER and ENGINEER access levels are listed below.

1 & 2 Zone Panels:

USER ACCESS CODE: 5 1 4

USER CONTROLS:

1. Silence Buzzer
2. Silence Alarms
3. Manual Evacuate
4. System Reset
5. Zone Isolate/De-isolate

ENGINEER'S ACCESS CODE: No access code, the upper panel cover must be removed to gain access to the switches.

1. One-Man-Test ON/OFF
2. Processor Reset
3. Zone 1 Non-Latch Enable/Disable

4 & 8 Zone Panels:

USER ACCESS CODE: 5 1 4

USER CONTROLS:

1. Silence Buzzer
2. Silence Alarms
3. Manual Evacuate
4. System Reset
5. Zone Isolate/De-isolate (Panel only)

ENGINEER'S ACCESS CODE: 5 3 2 4

1. One-Man-Test ON/OFF (button 1) (Panel only)
2. Earth Fault Monitoring Enable/Disable (button 2) (Panel only)
3. Processor Fault Reset (button 4)

The following Engineer's functions are available by removing the upper panel cover and setting the DIL Switches:

1. Number of connected Repeaters/Repeater Address
2. Zone 1 Non-Latch Enable/Disable (Panel only)