

*Discovery 1-4 Loop 32 Zone, 40 Character
Analogue Addressable Control Panel*

Application Guide

Contents

Page

1.0	<u>Introduction and Typical System Illustration</u>	2
2.0	<u>Cabinet Specifications</u>	4
3.0	<u>Hardware Specifications</u>	7
4.0	<u>Software Specifications</u>	14
5.0	<u>Panel Enhancements</u>	18
6.0	<u>Compatible Field Devices</u>	20

Appendices

i	<u>Other Relevant Documentation</u>	22
----------	--	-----------

1.0 Introduction and Typical System Illustration

The 32 Zone, 40 Character Discovery analogue addressable panel is available as a 1-4 loop panel using plug-in loop driver cards. Each loop is rated at 500mA and will control up to 126 Apollo, XP95 or Discovery devices. All addresses may be configured as cause/effect outputs, with up to 255 different programmable groups and 3 independently programmable output bits per address. Discovery mode changes are configured by the panel's internal clock and may differentiate between weekday and weekend functions. Loop inputs may also be configured to change selected loop devices between modes where temporary mode changes are required. Panels are housed in well-designed enclosures and are finished in hardwearing epoxy paint.

The motherboard electronics are fixed to a detachable chassis thus facilitating a completely empty enclosure for first fix installation. Top entry plastic grommets, bottom/rear entry knockouts for mains, and rear entry knockouts are designed to assist with cable installation.

The panel has a 4 line x 20 character backlit LCD display, showing device address, zone, type, status and location text. The LCD display provides capacity for 40 characters of user programmable device text. It is also used as a menu-driven engineers' configuration display. User controls are accessed by means of keyswitch enabled membrane controls, with password protection for engineer purposes.

The panel has 32 zonal LEDs are provided as standard and "plug-in" printer is available as an option.

The panel provides 2 common fire changeover relays and 1 common fault changeover relay, each rated at 1A, 30V DC. Four fully monitored panel inputs are provided for remote silence, remote reset, remote evacuate and remote fault. The evacuate input will operate the general alarms and may be programmed to operate the fire relay.

The Discovery panel may control up to 14 repeaters with full user capability via RS485 data comms. These repeater displays have 32 zonal LEDs.

Extensive panel and network cause/effect programming is achieved via the PC programming package.

Full networking with other 32 Zone, 40 Character Discovery panels, network repeaters and graphics package may be achieved with an additional plug-in network driver card. Network cause/effect may be programmed between 32 Zone, 40 Character Discovery, and active network repeaters.

2.0 Cabinet Specifications

2.1 Surface Cabinets

All cabinets are manufactured from 18SWG sheet steel and finished in satin texture epoxy powder stove paint. Top entry grommets and rear entry knockouts are provided.

Cabinet colour: RAL 7035 Light Grey

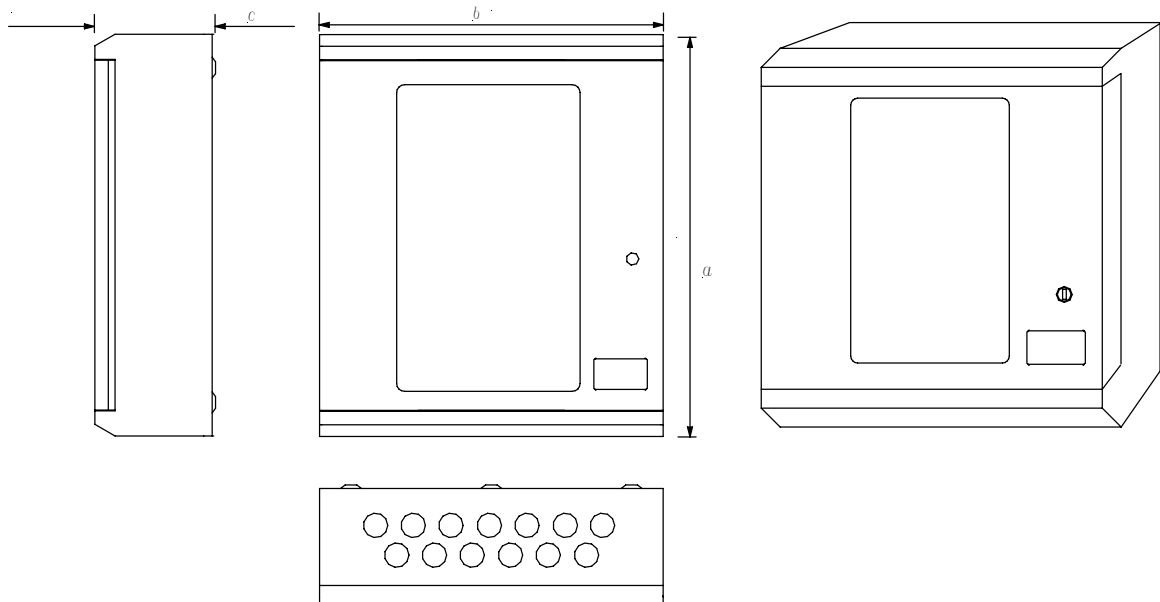

	1-4 loop	Repeaters
Protection Plugs	13 off	13 off
<i>a</i>	480mm	370mm
<i>b</i>	410mm	325mm
<i>c</i>	144mm	106mm

Part No	Description
2500/110	32 Zone, 40 Character Discovery 1 loop analogue/addressable control panel with 32 zone LEDs, c/w 1 loop card, expandable to 4 loops with 2500/130 Additional loop card; Cabinet size - 480h x 410w x 144d. Space for printer and 2 x 12V 12Ah battery set.
2500/111	32 Zone, 40 Character Discovery 2 loop analogue/addressable control panel with 32 zone LEDs, c/w 2 loop cards, expandable to 4 loops with 2500/130 Additional loop card; Cabinet size - 480h x 410w x 144d. Space for printer and 2 x 12V 12Ah battery set.
2500/112	32 Zone, 40 Character Discovery 3 loop analogue/addressable control panel with 32 zone LEDs, c/w 3 loop cards, expandable to 4 loops with 2500/130 Additional loop card; Cabinet size - 480h x 410w x 144d. Space for printer and 2 x 12V 12Ah battery set.
2500/113	32 Zone, 40 Character Discovery 4 loop analogue/addressable control panel with 32 zone LEDs, c/w 4 loop cards. Cabinet size - 480h x 410w x 144d. Space for printer and 2 x 12V 12Ah battery set.
2500/107	Printer
2500/130	Additional loop cards for Discovery panels

2.2 Semi-Flush Bezels

The semi-flush bezel locates to the rear of the bevelled edge of the back box, leaving the bevelled edge and door raised out from the wall.

Finished in the same colour as the cabinet back box and fitted by means of pinch bolts, thus avoiding the need to drill the cabinet.

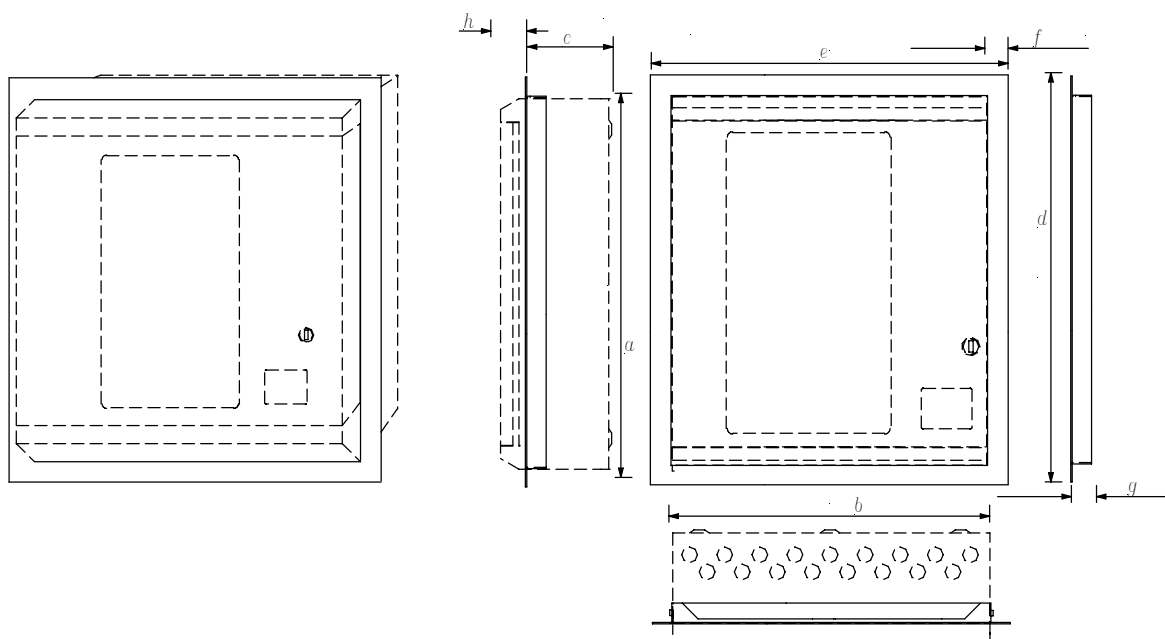

		1-4 loop	Repeaters
Hole Height	<i>a</i>	487mm	377mm
Hole Width	<i>b</i>	417mm	332mm
Hole Depth	<i>c</i>	114mm	76mm
Max Bezel Height	<i>d</i>	543mm	433mm
Max Bezel Width	<i>e</i>	473mm	388mm
Bezel Overlap	<i>f</i>	30mm	30mm
Bezel Depth	<i>g</i>	30mm	30mm
Door Protrusion	<i>h</i>	30mm	30mm

Part No	Description
2501/124	Semi-flush bezel for 32 Zone, 40 Character Discovery 1-4 loop panel and repeater panels 2500/844
2501/121	Semi-flush bezel for LCD repeater panels 2500/830 & 2500/842

2.3 Fully Flush Bezel

Fixed to the standard cabinet back box in place of the door and sized larger than the back box. Available in polished or brushed brass, stainless steel and painted finishes.

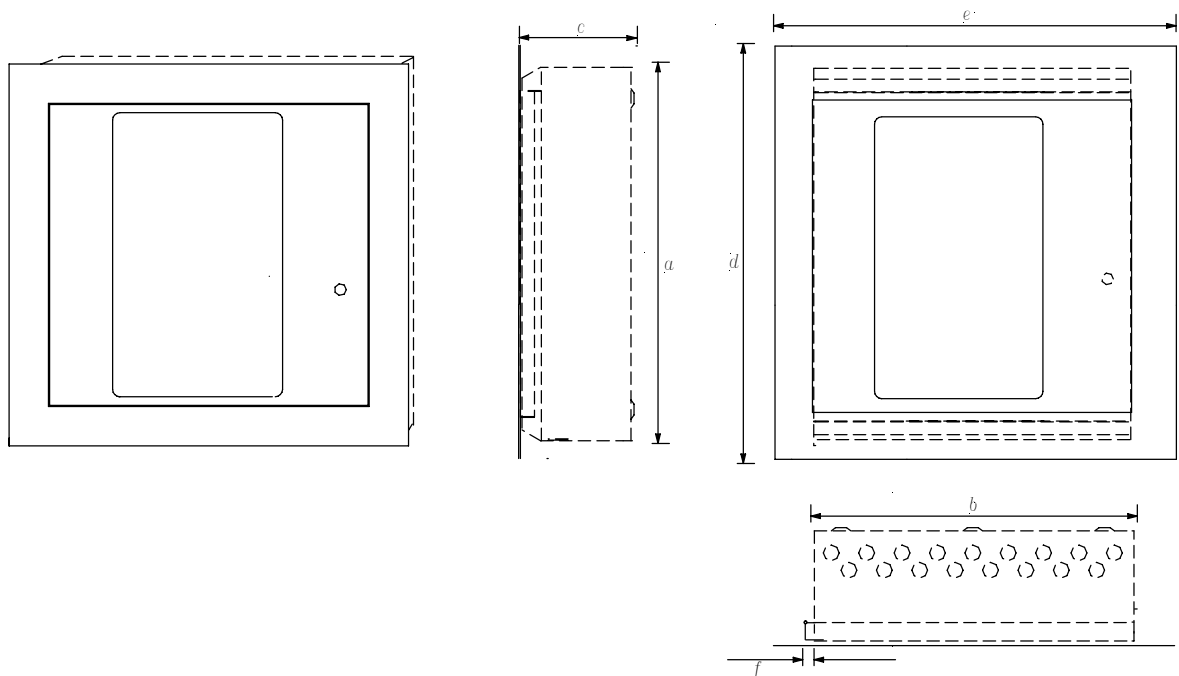

		1-4 loop	Repeaters
Hole Height	<i>a</i>	485mm	375mm
Hole Width	<i>b</i>	435mm	350mm
Hole Depth	<i>c</i>	144mm	106mm
Bezel Height	<i>d</i>	518mm	411mm
Bezel Width	<i>e</i>	486mm	423mm
Hinge Protrusion	<i>f</i>	20mm	20mm

Part No	Description
2501/153	Fully-flush painted bezel for 32 Zone, 40 Character Discovery 1-4 loop panel & large repeater panel 2500/844 (painted to customer's specification)
2501/154	Fully-flush stainless steel bezel for 32 Zone, 40 Character Discovery 1-4 loop panel & large repeater panel 2500/844 (brushed or polished)
2501/155	Fully-flush brass bezel for 32 Zone, 40 Character Discovery 1-4 loop panel & large repeater 2500/844 (brushed or polished)
2501/127	Fully-flush painted bezel for 32 Zone, 40 Character Discovery 1-4 loop repeater panel - 2500/830 & 2500/842 (painted to customer's specification)
2501/128	Fully-flush stainless steel bezel for 32 Zone, 40 Character Discovery 1-4 loop repeater panel - 2500/830 & 2500/842 (brushed or polished)
2501/129	Fully-flush brass bezel for 32 Zone, 40 Character Discovery 1-4 loop repeater panel - 2500/830 & 2500/842 (brushed or polished)

3.0 Hardware Specifications

3.1 Mechanical Assembly Illustration

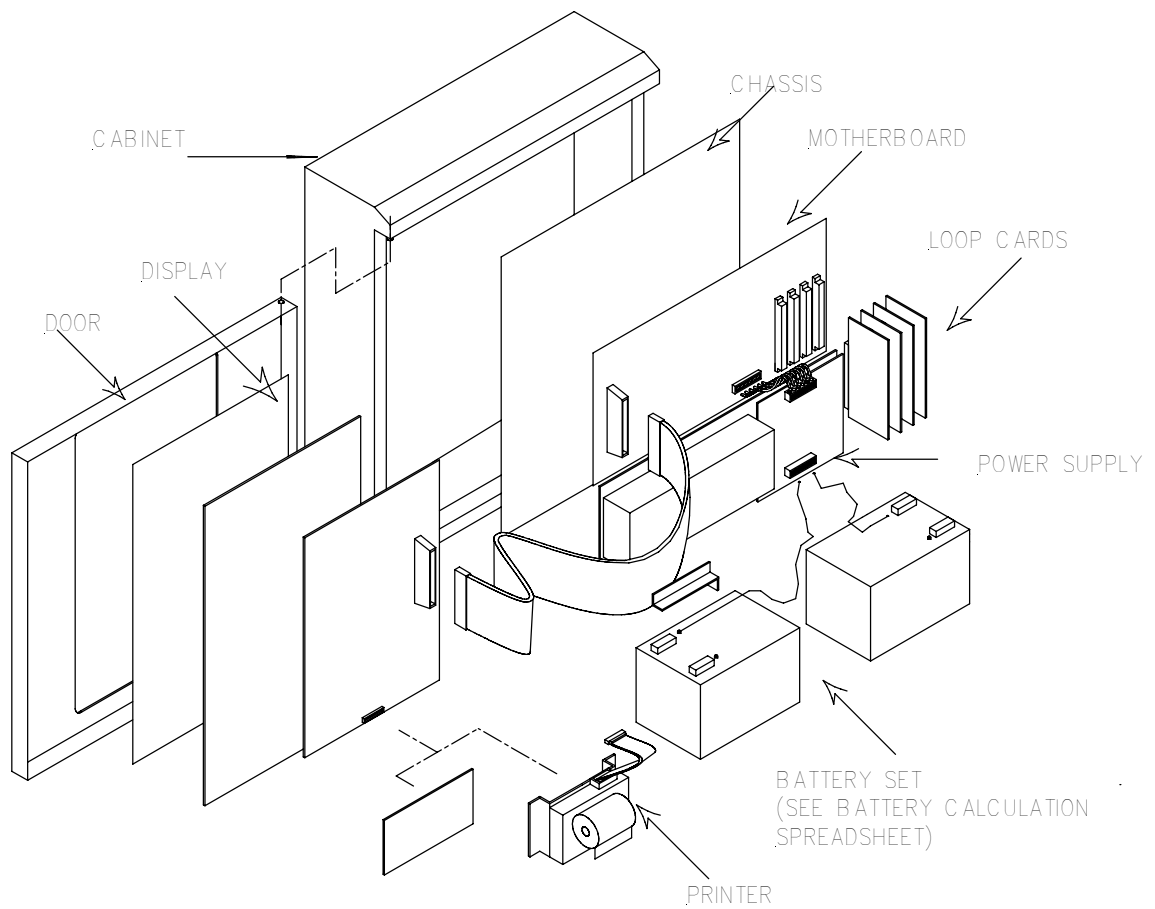

3.2 User Controls & Indications

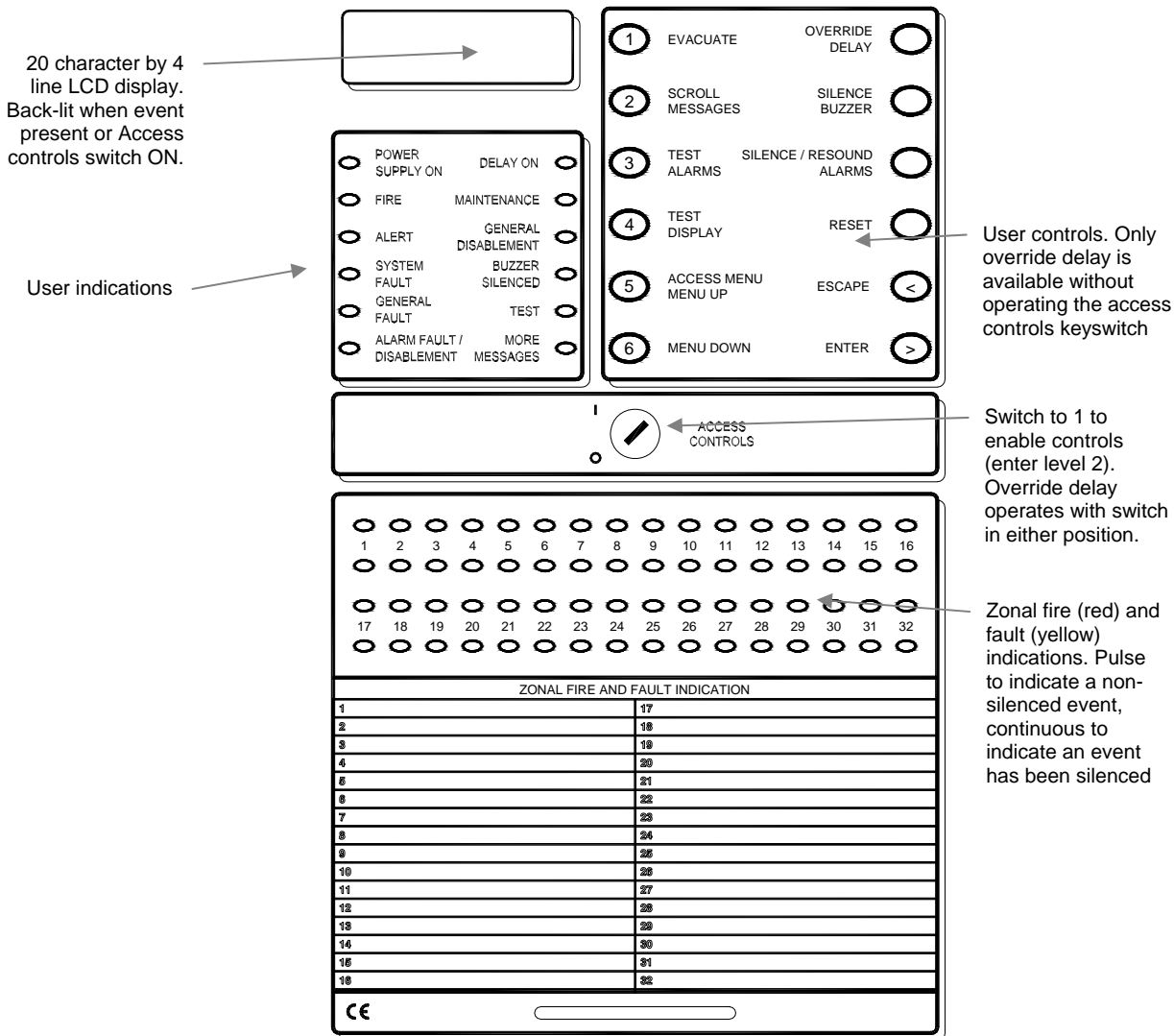

3.2.1 User Controls and Indications in Detail

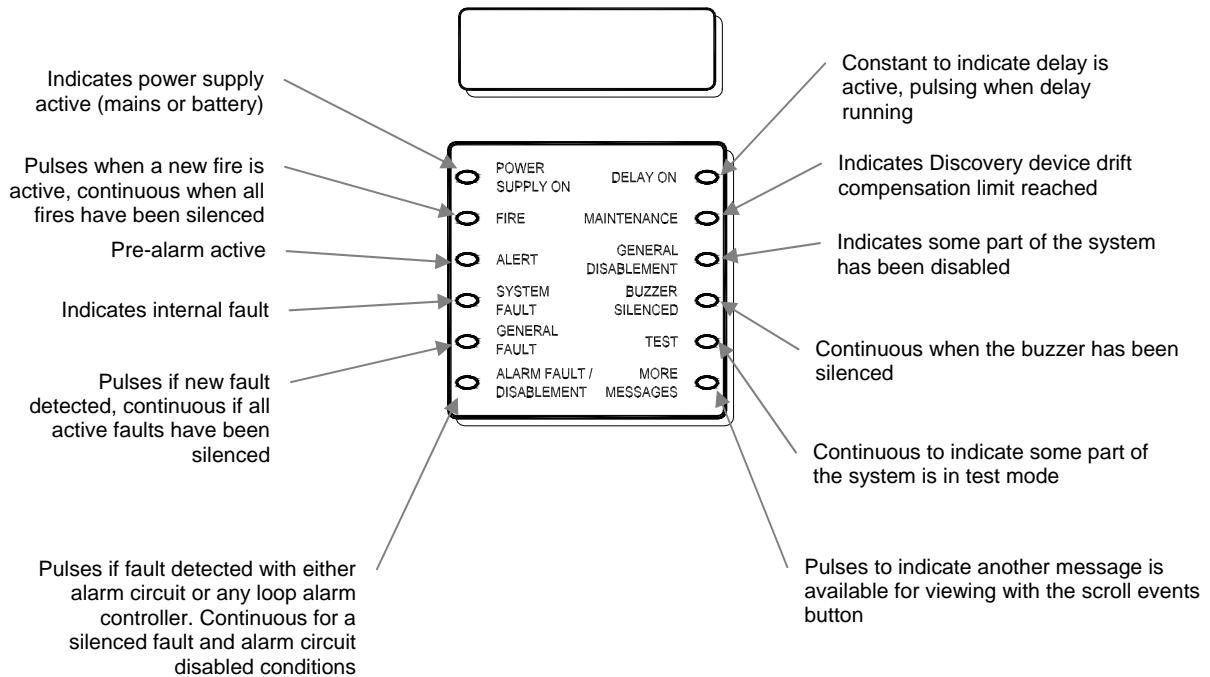
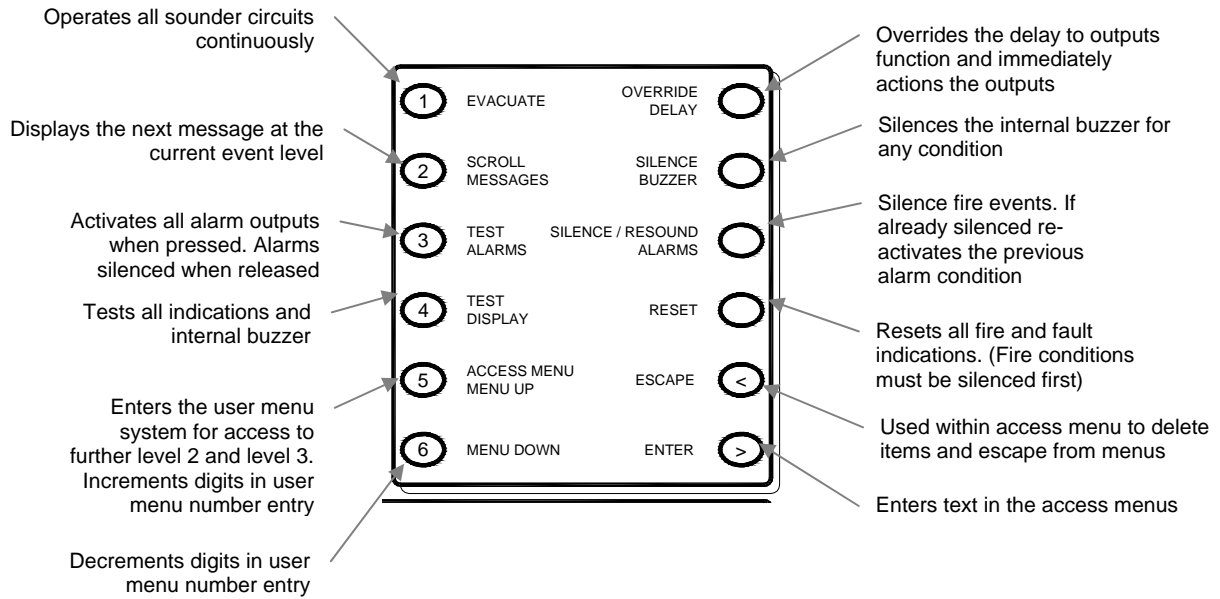

3.3 Engineer's Facilities

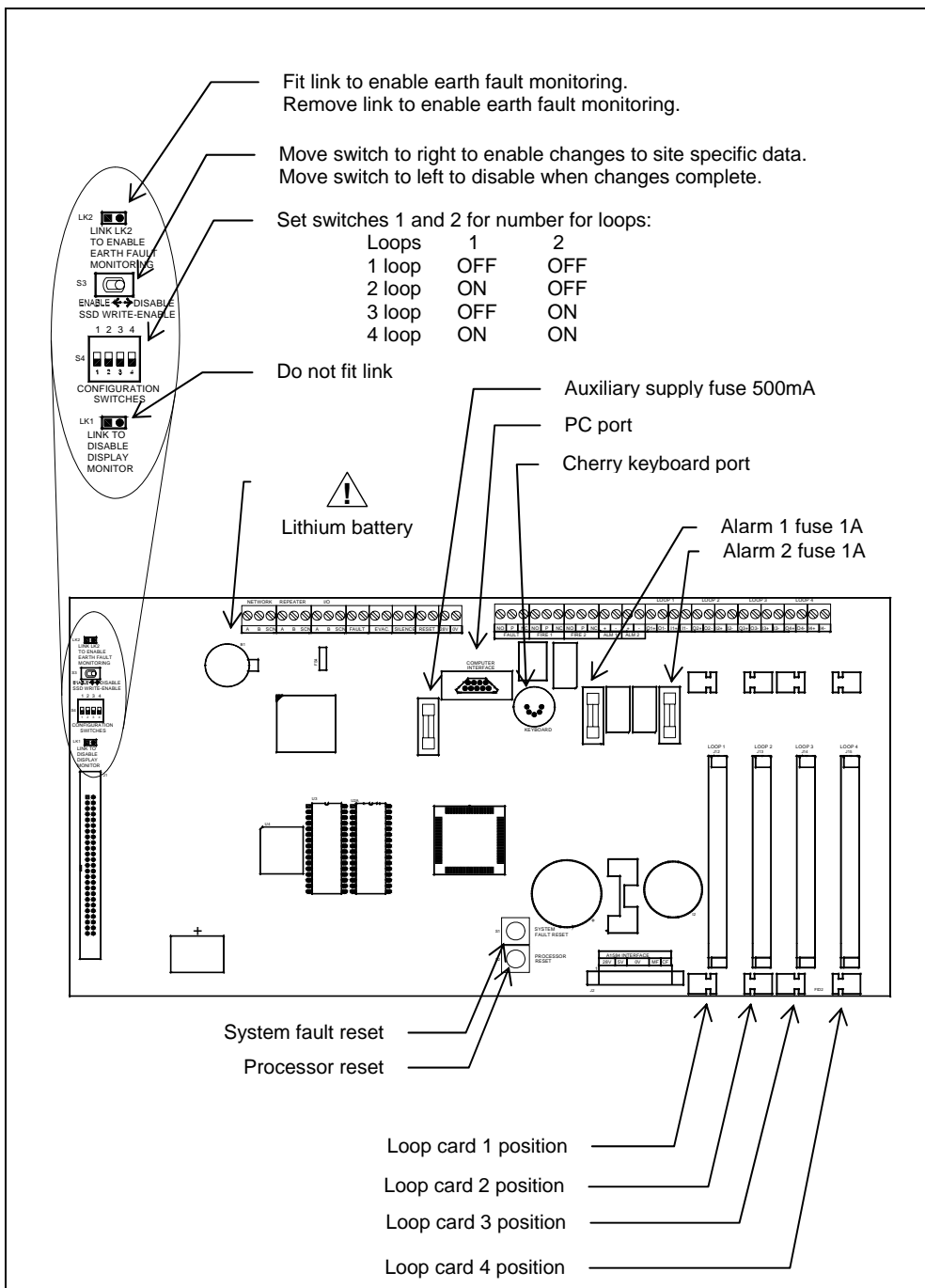

3.4 Power Supply

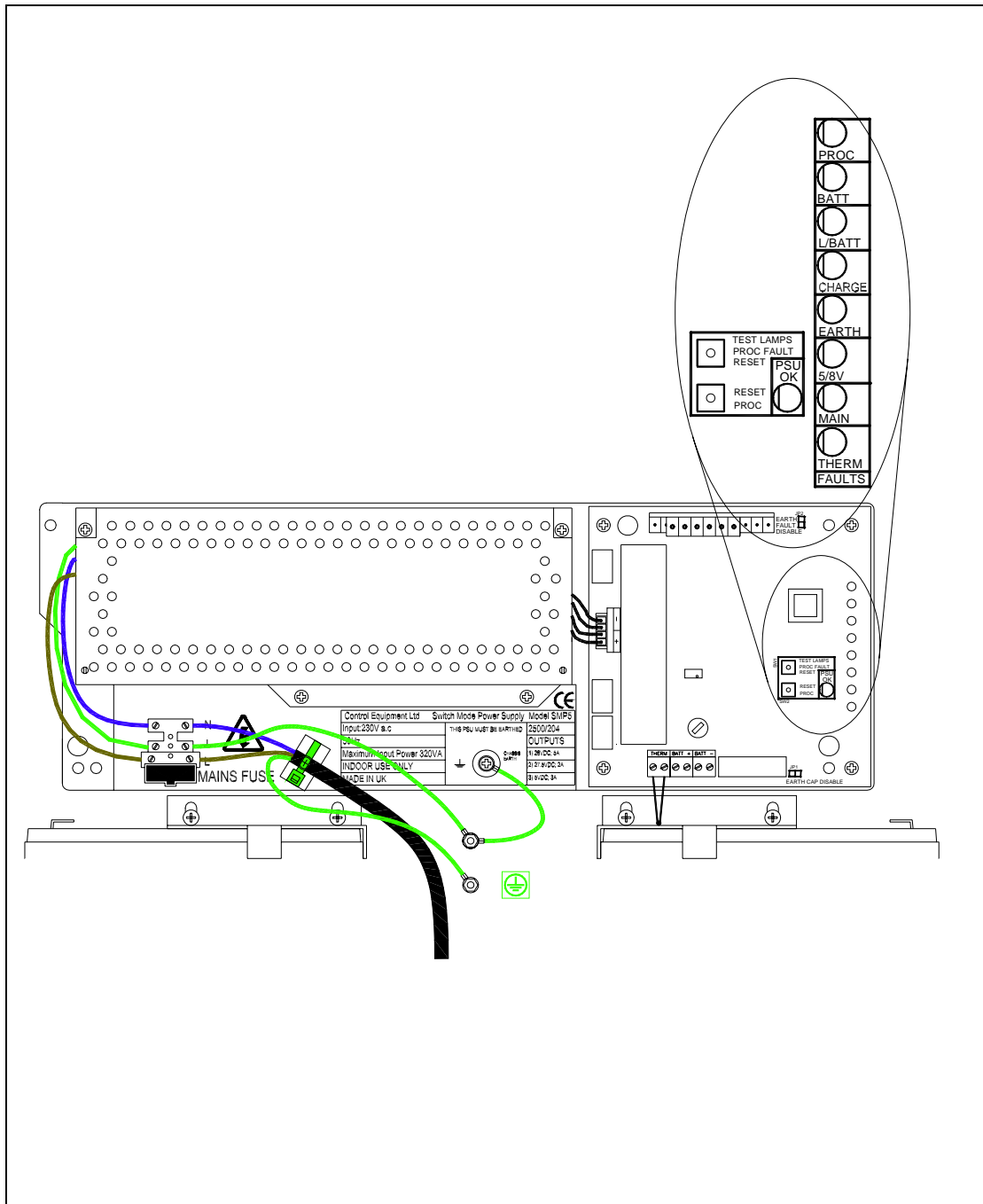

3.5 Use of Auxiliary Inputs

Auxiliary inputs are provided to allow remote operation of the following functions:

- Fault
- Evacuate
- Silence
- Reset

Each input circuit is fully monitored for open and short circuit faults. To activate an input a 680 ohm resistor should be connected across the input circuit by a normally open switch contact. Two switches are shown in Figure 1 although there is no limit to the number of switches.

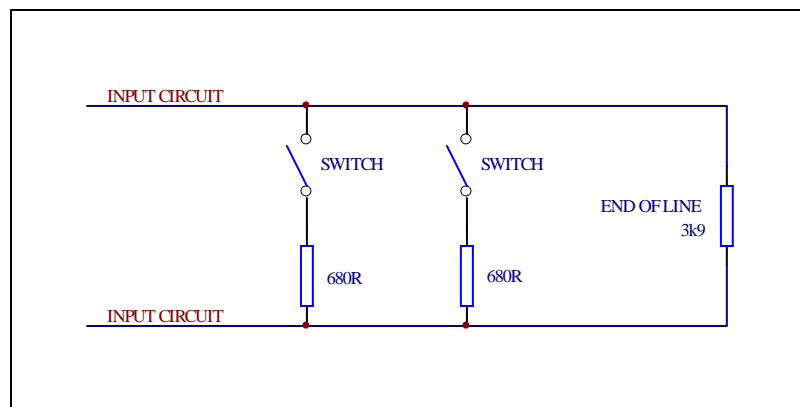

Figure 1 – Input circuit configuration

3.6 Alarm circuits

The **32 Zone, 40 Character Discovery** panel has two alarm circuits, each rated at 1A. The circuits are reverse polarity monitored for open and short circuit faults. To allow monitoring all devices must be polarised To prevent damage to the control panel bells must also be suppressed a bell fit diodes as shown in Figure 2. The circuit must be terminated with a 3k9 end of line resistor.

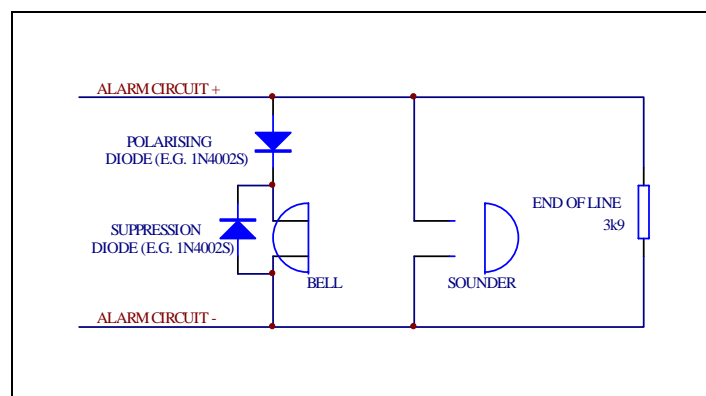

Figure 2 – Alarm circuit configuration

3.7 Mechanical and Environmental Specification

Size:	Height:	480mm
	Width:	410mm (2 loop and network repeater)
	Depth:	160mm including lock and indented holes
Weight excluding batteries:		15kg
Operating temperature:		-5°C to 40°C
Operating humidity:		5% to 95%

Electrical

Mains voltage: 230V AC +10%/-15%

Mains failed fault battery current:

1 Loop:	145mA
2 Loop:	170mA
3 Loop:	195mA
4 Loop:	220mA

Mains failed alarm battery current:

1 Loop:	260mA
2 Loop:	285mA
3 Loop:	310mA
4 Loop:	335mA

Battery charger type: Adjustable 27.5V float charger.

Maximum battery charging current: 1.5A

Battery type: 2 off 12V 12AH sealed lead acid standby battery

Battery size: 151mm x 98mm x 97.5mm

Panel inputs

Remote Fault: Fully monitored circuit, 3k9 EOL, 680R active

Remote Evacuate: Fully monitored circuit, 3k9 EOL, 680R active

Remote Silence: Fully monitored circuit, 3k9 EOL, 680R active

Remote Reset: Fully monitored circuit, 3k9 EOL, 680R active

Panel outputs

For each loop:	LO+	Loop out +ve
	LO-	Loop out -ve
	LI+	Loop return +ve
	LI-	Loop return -ve

Alarm circuits 2 at 1A per circuit

Auxiliary supply: 18.8V-28V @ 500mA

4.0 Software Specifications

4.1 Overview of Engineers Functions

This section describes an overview of the functions available to the end user.

4.1.1 Changing Time and Date

The user can manually set the time and date although this should not normally be required. The current time is maintained by a dedicated battery when all power removed from the system. How to set the time and date is described in the user manual.

4.1.2 Delay of Operation of Outputs

The activation of panel outputs (alarm circuit and cause effect) can be delayed upon detection of an automatic alarm condition to allow for the cause of the alarm to be investigated. The delay can be programmed for a period of between 1 and 10 minutes. The delay is active for one period every day, and off for the remainder of the time. This period is user definable and would typically be during working hours.

The delay is not operated if the alarm condition is initiated by a call point or the evacuate function. The delay may be overridden by a user function on the panel.

The engineer can set the delay start and end times, set the delay duration and enable or disable the delay.

4.1.3 Enabling Site Specific Data Changes

All site specific data is held in non-volatile memory. To protect this from errors the memory is protected by a write enable switch on the motherboard. This switch has to be set to the write enable position to allow any changes. If the switch is inadvertently left in the enable position when the changes are complete the panel indicates a fault condition.

4.1.4 Point Configuration

The panel loop devices can be automatically reconfigured through an engineers menu command. The panel stores each device address and type on configuration. Any changes to the loop devices are then indicated as a fault. The system configuration can also be printed out. This shows all devices on a loop with their current status.

The sensitivity of each point can also be changed to allow for ambient conditions. XP95 detectors can have the trip level for fire and alert configured. Discovery devices have the sensitivity code changed for fire sensitivity and the analogue threshold for alert can be changed.

Note: For compliance with EN54 the fire sensitivity level must be set to 55. The pre-alarm value can be set to any value

Note: Do not adjust the fire sensitivity level of the XP95 high temperature heat detector. This device has an analogue count of 55 at 90 C.

Note: The default levels are:

	<i>XP95 sensor</i>	<i>Discovery sensor</i>
<i>Default Alert level</i>	<i>45</i>	<i>45</i>
<i>Default Fire level</i>	<i>55</i>	<i>55</i>
<i>Valid Alert Levels</i>	<i>35, 40, 45, 50</i>	<i>35, 40, 45, 50</i>
<i>Valid fire levels</i>	<i>55, 60, 65, 70</i>	<i>55</i>
<i>Default sensitivity levels</i>	<i>N/A</i>	<i>3</i>
<i>Valid sensitivity levels</i>	<i>N/A</i>	<i>1, 2, 3, 4, 5</i>

All ancillary devices have fixed responses except the Apollo Input Output module. The input for this device can be configured for response as a fire, fault, alert or indication only.

4.1.5 Discovery Device Functions

The following functions are available with Apollo Discovery devices:

- Print drift compensation level by loop
- Print device date of manufacture
- Enable or disable LED pulsing mode

4.1.6 Zone Allocation

The 32 Zone, 40 Character Discovery has 32 programmable zones. All loop devices and panel inputs can be programmed into one of these zones through the engineers menu. Activation of a fire or a fault on a device will cause operation of the fire or fault indicator associated with the zone. The panel alphanumeric display will also indicate the zone number. The panel has an insert fitted to the front door suitable for text descriptions of each zone location.

The engineer can also print out all the zones with the devices allocated to the zones.

4.1.7 Programmable Cause/Effect

Any loop device output can be individually programmed to operate in response to a common event or a zone or group entering a specific condition.

The common events are: -

- Common fire, output cleared on reset
- Common fire, output cleared on silence alarms
- Common alert, output cleared on reset
- Common fault, output cleared on reset
- Common indication, output cleared on reset
- Alarms silenced
- Panel reset
- Evacuate (including remote evacuate)

The zone and group based events can occur on any device, or devices within the specified zone or group: -

- Fire in a group or zone, output cleared on silence alarms.
- Fire in a group or zone, output cleared on reset.
- Any two fires in a group or zone, output cleared on silence alarms.
- Any two fires in a group or zone, output cleared on reset.
- Alert in a group or zone, output cleared on reset.
- Fault in a group or zone, output cleared on reset.
- Indication in a group or zone, output cleared on reset.

A group contains device points in the same way as a zone but the group is used solely for cause effect programming.

4.2 Overview of Engineer's Menu Options

Operate Access Controls Key Switch followed by the following: -

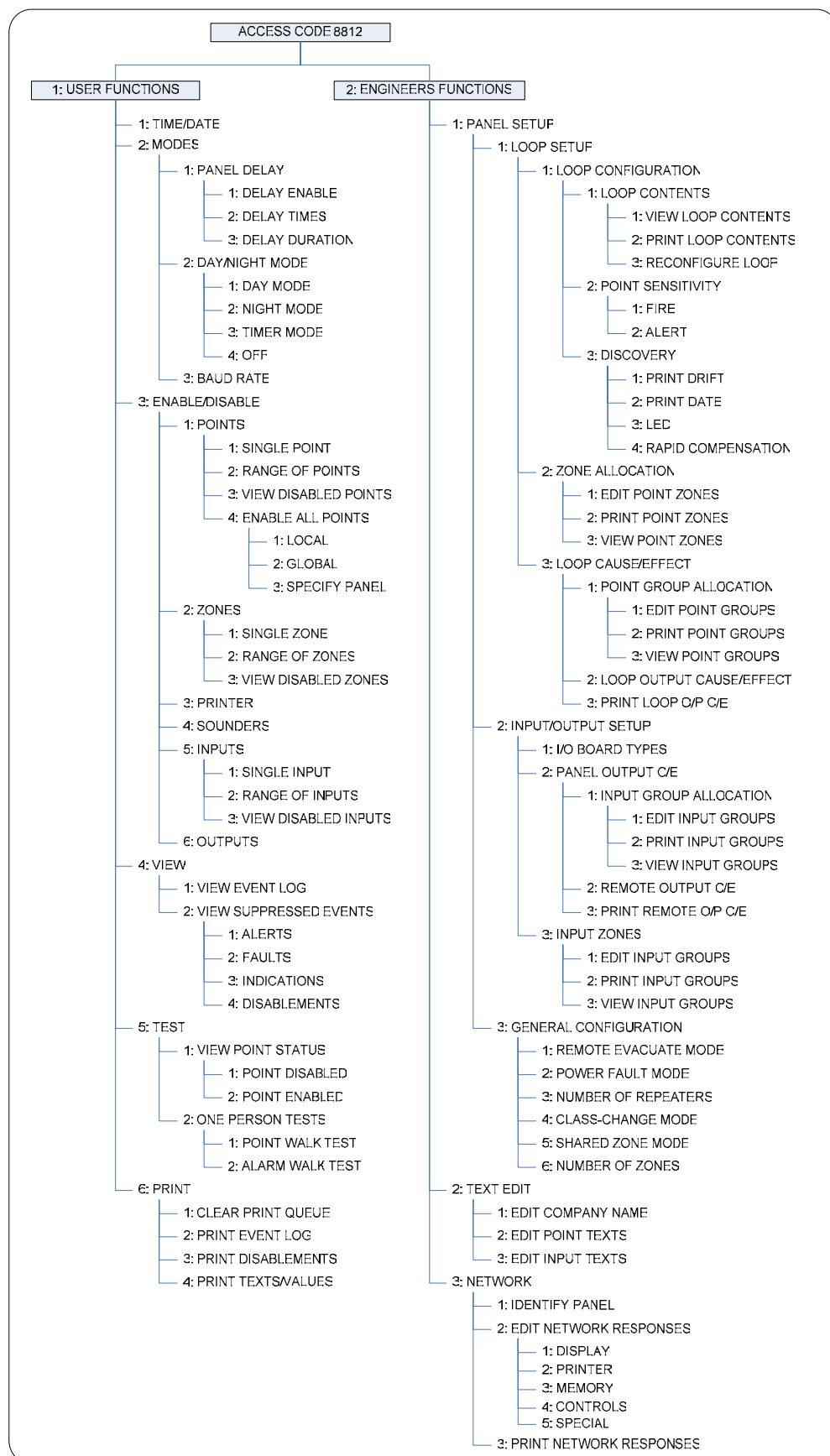

5.0 Panel Enhancements

The 32 Zone, 40 Character Discovery 1-4 loop panel may be enhanced to provide additional facilities. Other relevant documentation is available providing more details.

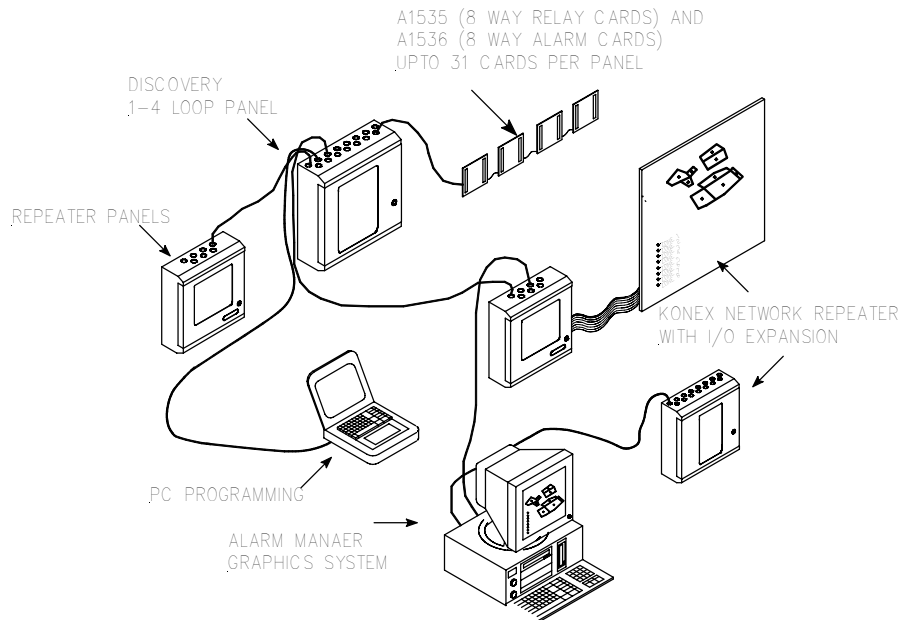

Note: This is an illustration only and not wiring schematic.

A secondary cabinet is usually required for all PCBs.

5.1 Panel Enhancement Order Codes & Descriptions

Part No	Description
2500/157	A1535 programmable expansion board - 8 open inputs & 8 relay outputs
2500/158	A1536 programmable expansion board - 8 open inputs & 8 alarm outputs
2500/221	Enclosure c/w 3A psu & space for 6.2AH battery set & 2 or 4 panel programmable expansion boards (A1535 or A1536)
2500/223	Enclosure c/w 5A psu & space for 6.2AH battery set & 2 or 4 panel programmable expansion boards (A1535 or A1536)
2500/107	Printer
2500/198	1A 24V DC door retainer power supply unit in enclosure (no battery back-up) Size - 300h x 350w x 75d
2500/197	MPC1 1A power supply unit in enclosure with space for 3.2AH battery set Size 300h x 350w x 75d
2500/199	MPC3 3A power supply unit in enclosure with space for 12AH battery set Size 355h x 370w x 90d
2500/200	MPC5 5A power supply unit in enclosure with space for 24AH battery set Size 300h x 360w x 190d
2500/201	10A Switch mode power supply unit in enclosure with space for 12AH battery set Size 600h x 380w x 210d

5.1.2 A1535/A1536 8 Way Expansion Boards

Up to 31 (A1535 & A1536) 8 way programmable expansion boards may be connected to each 32 Zone, 40 Character Discovery 1-4 loop panel. A special 2 door cabinet is available to house up to 4 enhancement boards (details on request). Up to 31 boards in total may be connected via an RS485 comms - for local expansion only. Local power is required for each board in addition to the RS485 comms link.

WARNING: *In order to conform to the requirements of BS5839 / EN54, the A1536 8 way alarm board must be used adjacent to the main panel.*

The inputs and outputs are fully programmable within the panel's cause/effect facility. The output type (eg relays or alarm circuits) are determined by the board type chosen. The inputs may be monitored or non-monitored, or indication only.

Please refer to A1535 8 Way Relay Board & A1536 8 Way Alarm Board documentation for further details.

5.2 Battery Sizes (YUASA)

Battery Rating	Battery Size
3.2Ah battery 12V	134mm long x 67mm wide x 64mm high
6.2Ah battery 12V	151mm long x 65mm wide x 97.5mm high
12Ah battery 12V	151mm long x 98mm wide x 97.5mm high
15Ah battery 12V	181mm long x 98mm wide x 167mm high
38Ah battery 12V	166mm long x 175mm wide x 125mm high
65Ah battery 12V	350mm long x 166mm wide x 174mm high

6.0 Compatible Field Devices

The 32 Zone, 40 Character Discovery is compatible with the devices listed in this section
Field Device Order Codes & Descriptions

Part No	Description
2501/270	58000-500 Discovery Ionisation smoke detector (Apollo manufacture)
2501/271	58000-600 Discovery Optical smoke detector (Apollo manufacture)
2501/272	58000-400 Discovery Heat detector (Apollo manufacture)
2501/273	58000-700 Discovery Multisensor (Apollo manufacture)
2501/274	58000-900 Discovery Manual call point (Apollo manufacture)
2501/022	55000-500 XP95 Ionisation smoke detector (Apollo manufacture)
2501/023	55000-600 XP95 Optical smoke detector (Apollo manufacture)
2501/024	55000-400 XP95 Temperature detector - standard (Apollo manufacture)
2501/020	45681-210 XP95 Base complete with address card (Apollo manufacture)
2501/019	55000-900 XP95 Manual call point (Apollo manufacture)
2501/027	55000-700 XP95 Isolator (Apollo manufacture)
2501/026	45681-211 XP95 Isolator base (Apollo manufacture)
2501/218	45681-321 XP95 Isolating base, 20 devices (Apollo manufacture)
2501/021	55000-401 XP95 Temperature detector - high temperature (Apollo manufacture)
2501/275	55000-818 XP95 Input/Output unit (Apollo manufacture)
2501/217	55000-819 XP95 Output unit (Apollo manufacture)
2501/276	55000-810 XP95 Switch monitor (Apollo manufacture)
2501/277	55000-809 XP95 Switch monitor plus (Apollo manufacture)
2501/278	55000-813 XP95 Zone monitor (Apollo manufacture)
2501/279	55000-823 XP95 Sounder control unit (Apollo manufacture)
2501/280	55000-833 XP95 Mini switch monitor (Apollo manufacture)
2501/216	55000-832 XP95 Mini switch monitor – interrupt (Apollo manufacture)
2501/281	55000-803 XP95 DIN rail mounted input/output unit (Apollo manufacture)
2501/282	55000-804 XP95 DIN rail mounted Output unit (Apollo manufacture)
2501/283	55000-822 XP95 DIN rail mounted switch monitor (Apollo manufacture)
2501/284	55000-821 XP95 DIN rail mounted switch monitor plus (Apollo manufacture)
2501/285	55000-812 XP95 DIN rail mounted zone monitor (Apollo manufacture)
2501/286	55000-826 XP95 DIN rail mounted sounder control unit (Apollo manufacture)
2501/287	55000-802 XP95 DIN rail mounted isolator (Apollo manufacture)
2501/221	45681-261 XP95 Loop sounder requires XP95 base (Apollo manufacture)
2501/222	55000-260 XP95 Loop sounder with red cap (Apollo manufacture)
2501/223	55000-259 XP95 Loop sounder with white cap (Apollo manufacture)
2500/235	CEL Addressable break glass unit (no back box)
2500/236	A1444 basic outstation board (3 inputs)
2500/237	A1445 relay outstation board (3 inputs, 3 relays)
2500/238	A1446 sounder outstation board (3 inputs, 1 sounder circuit, 1 relay)

Part No	Description
2500/240	A1447 add-on zone monitor board for above outstation boards
2501/149	Enclosure to fit 1 outstation board; Size - 150h x 225w x 75d
2500/197	Enclosure c/w 1A p.s.e., space for one outstation board & 3.2Ah batteries Size - 300h x 350w x 75d
2500/221	Enclosure c/w 3A p.s.e., space for four outstation boards & 6.2Ah batteries Size - 380h x 600w x 210d
2500/223	Enclosure c/w 5A p.s.e. & space for five outstation boards & 6.2Ah batteries Size - 600h x 600w x 210d
2500/226	Remote square indicator
2500/227	Remote round indicator
2500/232	Loop powered sounder; maximum 16 per loop
	55000-780 XP95 RDM Interface (Apollo manufacture)
	55000-580 XP95 RDM Ionisation smoke detector (Apollo manufacture)
	55000-680 XP95 RDM Optical smoke detector (Apollo manufacture)
	55000-480 XP95 RDM Heat detector (Apollo manufacture)
	45681-280 XP95 RDM Base (Apollo manufacture)
	55000-265 XP95 Loop powered beam detector (Apollo manufacture)
	45681-242 XP95 Low power relay base (Apollo manufacture)
	55000-855 XP95 Protocol translator – single channel (Apollo manufacture)
	55000-856 XP95 Protocol translator – dual channel (Apollo manufacture)
	55000-540 XP95 I.S. Ionisation smoke detector (Apollo manufacture)
	55000-640 XP95 I.S. Optical smoke detector (Apollo manufacture)
	55000-440 XP95 I.S. Temperature detector - standard (Apollo manufacture)
	55000-940 XP95 I.S. Manual call point (Apollo manufacture)
	45681-215 XP95 I.S. Base (Apollo manufacture)
2601/034	CEL platform sounder (XP95/Discovery detector base)
2601/035	CEL platform sounder (Xplorer detector base)
2601/041	55000-261 100dB Loop sounder (Apollo manufacture)
	45681-262 Loop sounder with isolating base (Apollo manufacture)
	55000-280 XP95 flame detector (Apollo manufacture)
	55000-852 XP95 sounder controller unit with isolator (Apollo manufacture)
	Din rail zone monitor unit with isolator (Apollo manufacture)
	55000-843 XP95 switch monitor with isolator (Apollo manufacture)
	55000-841 XP95 switch monitor plus with isolator (Apollo manufacture)
	55000-847 XP95 I/O unit with isolator (Apollo manufacture)
	55000-849 XP95 output unit with isolator (Apollo manufacture)
	55000-589 XP95 3 channel I/O unit
	55000-588 XP95 3 channel I/O unit with isolator
2501/253	55000-885 XP95 Multi-Sensor (Apollo manufacture)
	55000-875 XP95 Mains Switching I/O Unit (Apollo manufacture)
	55000-845 XP95 Zone Monitor with Isolator (Apollo manufacture)
	58000-300 Discovery CO Detector (Apollo manufacture)
	55000-268 Reflective beam detector [5-50m]
	55000-273 Reflective beam detector [50-100m]
	55000-878 Loop Powered Beacon (Apollo manufacture)
	45681-265 Intelligent Base Sounder (Apollo manufacture)
	Integrated Base Sounder (Apollo manufacture)

Part No	Description
	Vesda Aspirating Smoke Detector
	XP95 Sounder Beacon Base (Apollo manufacture)

6.2 General Accessories' Order Codes & Descriptions

Part No.	Description
2501/040	150mm bell (24 volts DC)
2501/044	Roshni Electronic Sounder (24 volts DC) Deep Base (IP65)
2501/055	Roshni Electronic Sounder (24 volts DC) Shallow Base (IP54)
2501/048	Squashni Sounder and Base
2501/049	Cover Plate for Squashni Sounder
2501/056	White Bedhead Sounder
2501/043	Xenon flashing beacon (24 volts DC - 2 watts)
2501/033	Door retainer (24 volts DC)
2501/034	Door retainer (240 volts AC)
2501/035	Door retainer floor bracket

Appendices

i Other Relevant Documentation

Sales Literature

32 Zone, 40 Character Discovery 1-4 Loop Installation and Commissioning Manual

32 Zone, 40 Character Discovery 1-4 Loop User Instructions

Wiring Recommendations

PC-based Software Programming Guide

Battery Calculation spreadsheet