

# CB200 Conventional Control Panel Application Guide

## Contents

1. Cabinet Specifications .....	2
2. Panel Hardware Specifications.....	3
3. Panel Configuration .....	4
4. Technical Specifications .....	6
5. CB200 Panel Enhancements.....	8
6. CB200 Panel Compatible Zone Devices .....	9
7. Additional Available Documentation .....	10

## 1. Cabinet Specifications

All cabinets are manufactured from polycarbonate with a satin textured finish. Eleven top entry grommets are provided on a removable gland plate.

Cabinet colour: RAL7035 Textured (light grey)

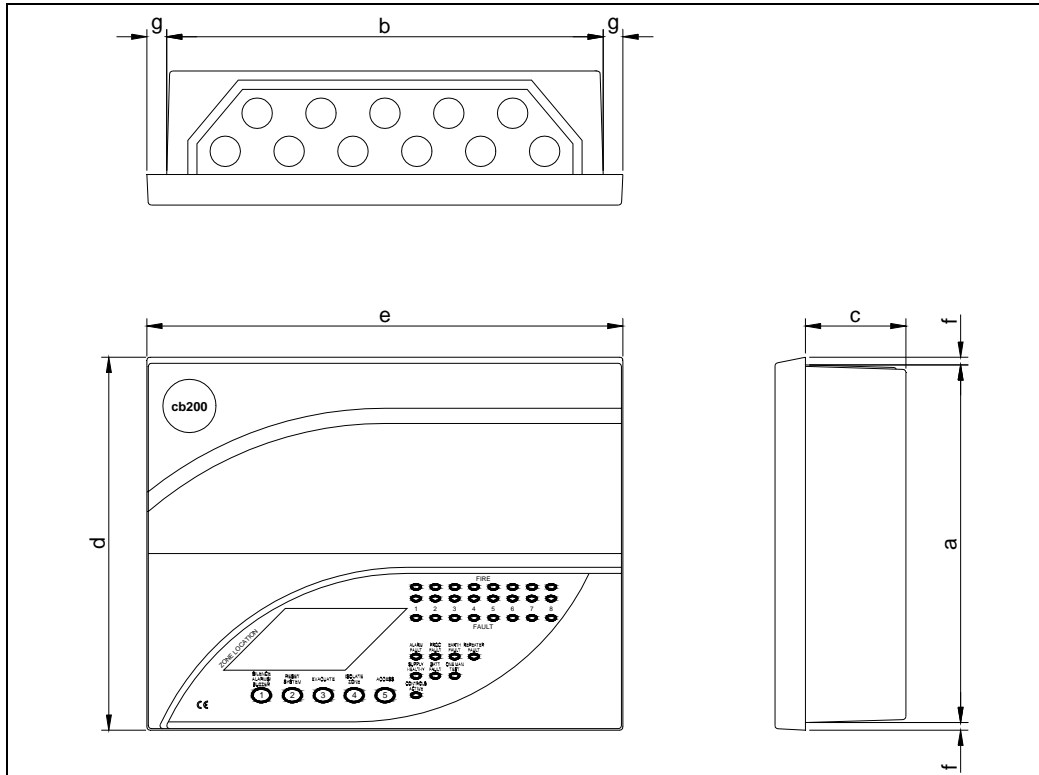

	Description	Size
a	Back box height	235mm
b	Back box width	287mm
c	Back box depth	66mm
d	Front cover height	245mm
e	Front cover width	313mm
f	Bezel overhang - top/bottom	5mm
g	Bezel overhang - left/right	13mm
	Protection plugs = 11	

### 1.1.1 Order Codes & Descriptions

Part No	Description
2500/383	CB200 1 zone conventional control panel
2500/384	CB200 2 zone conventional control panel
2500/385	CB200 4 zone conventional control panel
2500/386	CB200 8 zone conventional control panel
2500/967	CB200 8 zone repeater with power supply
2500/968	CB200 8 zone repeater powered from panel

## 2. Panel Hardware Specifications

### 2.1 User Controls and Indications (8 zone illustrated)

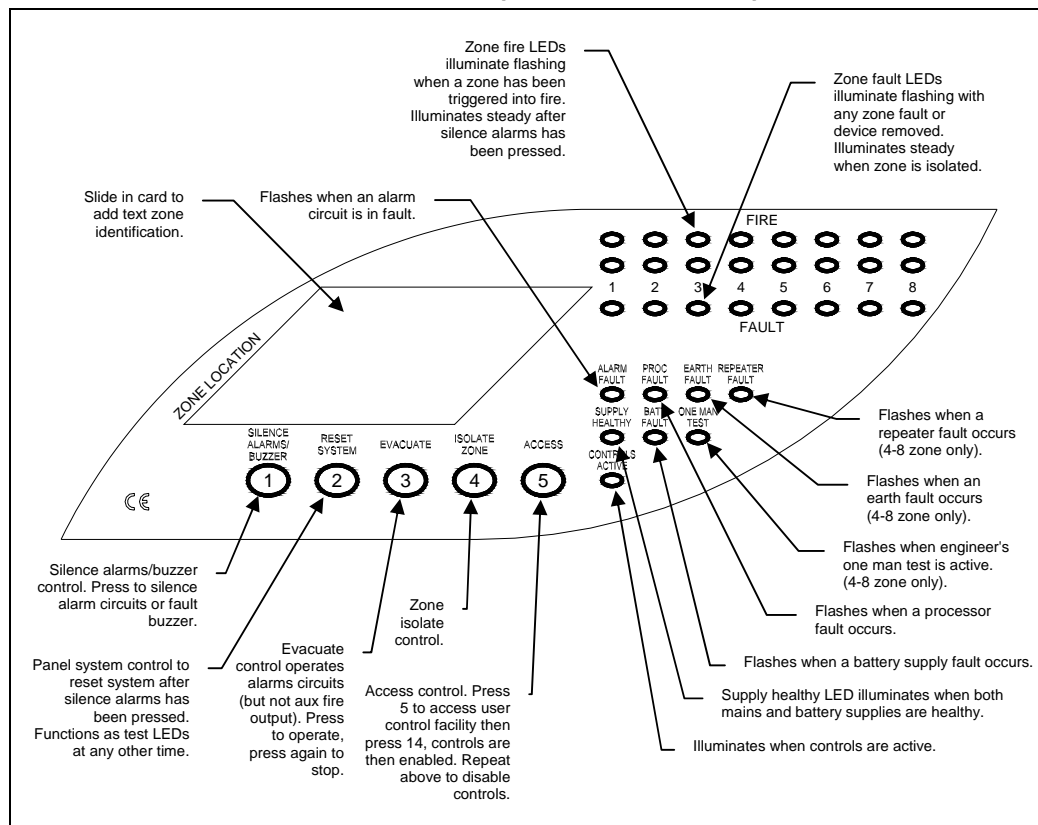

## 2.2 Engineer Facilities

### 2.2.1 Mechanical Assembly Illustration

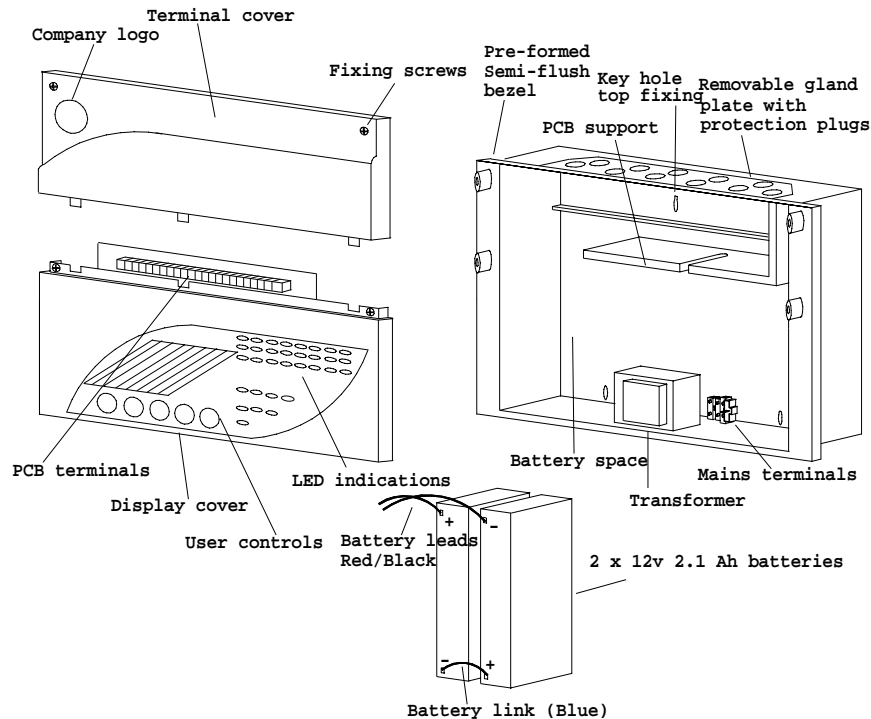

## 3. Panel Configuration

### 3.1 Buzzer Enable Link

The "Link for Buzzer Enable" link, located at the top right corner of the Control Board, is a buzzer disable/enable facility. Its purpose is to disable the buzzer should this be helpful during commissioning. **DO NOT** remove this link except in exceptional circumstances. This link is not monitored by the control board and no faults or indications of any kind will be generated if the link is removed.

### 3.2 Engineer's Control:- 1-2 Zone Panels

This facility is located on the top right hand corner of the PCB. Its functions are described below:

#### 3.2.1 Processor Reset

Press to reset if the "Processor Fault" LED illuminates

#### 3.2.2 One-man Test

If pressed for more than 5 seconds the panel will go into One-man Test mode.

#### 3.2.3 Zone 1 Non-latch

Setting the zone 1 non-latch DIL switch to the ON position causes zone 1 to operate in a non-latching fire indication mode. In this mode, if a fire condition occurs on zone 1 the panel will indicate the fire condition and operate the alarms. The auxiliary fire

relay contacts will not be operated. If the fire condition is cleared from zone 1 then the zone 1 fire indication is cleared and, as long as no other zones are in fire, the alarms are also cleared. If any other zone is in a fire condition the panel will remain in the fire condition until manually reset.

### **3.2.4 Class Change Input**

This input is not fault monitored and is normally open. When a short circuit is placed across input terminals the panel operates the alarm circuits and internal buzzer. The input is non-latching.

### **3.3 Engineer's Controls:- 4-8 Zone Panels**

The following functions are available through the Engineer's Access Code:

- i) One-man Test
- ii) Earth Fault enable/disable
- iii) Clear Processor Fault indication – if the processor stops, the "Proc. Fault" LED will illuminate. The processor will start automatically unless there is a hardware fault.

### **3.4 CB200 Repeater Panel**

A repeater panel is available for the CB200 4 and 8 zone panels. This is connected using RS485 serial communications over a screened twisted pair cable. Up to 3 repeaters can be connected to the control panel and provide the following features at a remote location:

- Indication of zonal fire, zonal fault and zonal isolate conditions
- Operation of Buzzer Silence, Manual Evacuate, Alarms Silence and System Reset functions
- Indication of control panel status
- Indication of communication fault with control panel
- Indication of local power supply fault (if fitted)
- Indication of power supply fault on another repeater (steady Batt. Fault LED)
- Indication of a communication fault on another repeater. (Steady Comms. Fault LED)
- NOTE: Only one repeater can be powered from the 24VDC supply output on the control panel.

### **3.5 Repeater Configuration**

The following configuration is associated with the repeater:

- Number of repeaters connected to panel (on panel)
- Repeater address (on each repeater)

## **4. Technical Specifications**

### **CB200 1-2 zone control panel**

Maximum field equipment load:	800mA
Auxiliary 24VDC output	250mA
Mains failed current consumption:	35mA
Integral charger output:	500mA
Common fire output:	Volt- free contacts - 1A, 30V DC max.
Common fault output:	Volt- free contacts - 1A, 30V DC max.
Alarm circuit output:	2 at 250mA each
Battery size:	2 x 12V 2.1AH sealed lead acid
Weight (excluding batteries):	2.3kg

### **CB200 4 zone control panel**

Maximum field equipment load:	800mA
Auxiliary 24VDC output	250mA
Mains failed current consumption:	40mA
Integral charger output:	500mA
Common fire relay:	Volt- free contacts - 1A, 30V DC max.
Common fault output:	Volt- free contacts - 1A, 30V DC max.
Alarm circuit output:	4 at 500mA each
Battery size:	2 x 12V 2.1AH sealed lead acid
Weight (excluding batteries):	2.3kg

### **CB200 8 zone control panel**

Maximum field equipment load:	800mA
Auxiliary 24VDC output	250mA
Mains failed current consumption:	40mA
Integral charger output:	500mA
Common fire relay:	Volt- free contacts - 1A, 30V DC max.
Common fault output:	Volt- free contacts - 1A, 30V DC max.
Alarm circuit output:	4 at 500mA each
Battery size:	2 x 12V 2.1AH sealed lead acid
Weight (excluding batteries):	2.4kg

### **CB200 8 zone repeater panel with power supply**

Mains failed current consumption:	40mA @24VDC
Integral battery charger output:	500mA @27.5VDC
Auxiliary 24VDC output	250mA
Battery size:	2 x 12V 2.1AH sealed lead acid
Weight (excluding batteries):	2.4kg

### **CB200 8 zone control panel powered from panel**

Current consumption:	40mA @24VDC
Weight:	1.4kg

### RS485 Cable Specification

Generic Type: RS422/RS485 data cable.  
 Conductors: Single pair plus screen.  
 Alpha cable: 3492C, 6222C, 6412 or equivalent  
 Belden cable: 8102, 8132, 9841 or equivalent

**NOTE:**

On 4 and 8 zone panels the total available current for field devices is 800mA at 28VDC. This current must be shared between the auxiliary 24VDC supply and the four alarm circuits such that the total current drain across the five circuits does not exceed 800mA.

### 4.1 Typical Terminal Wiring Schematic (8 zone illustrated)

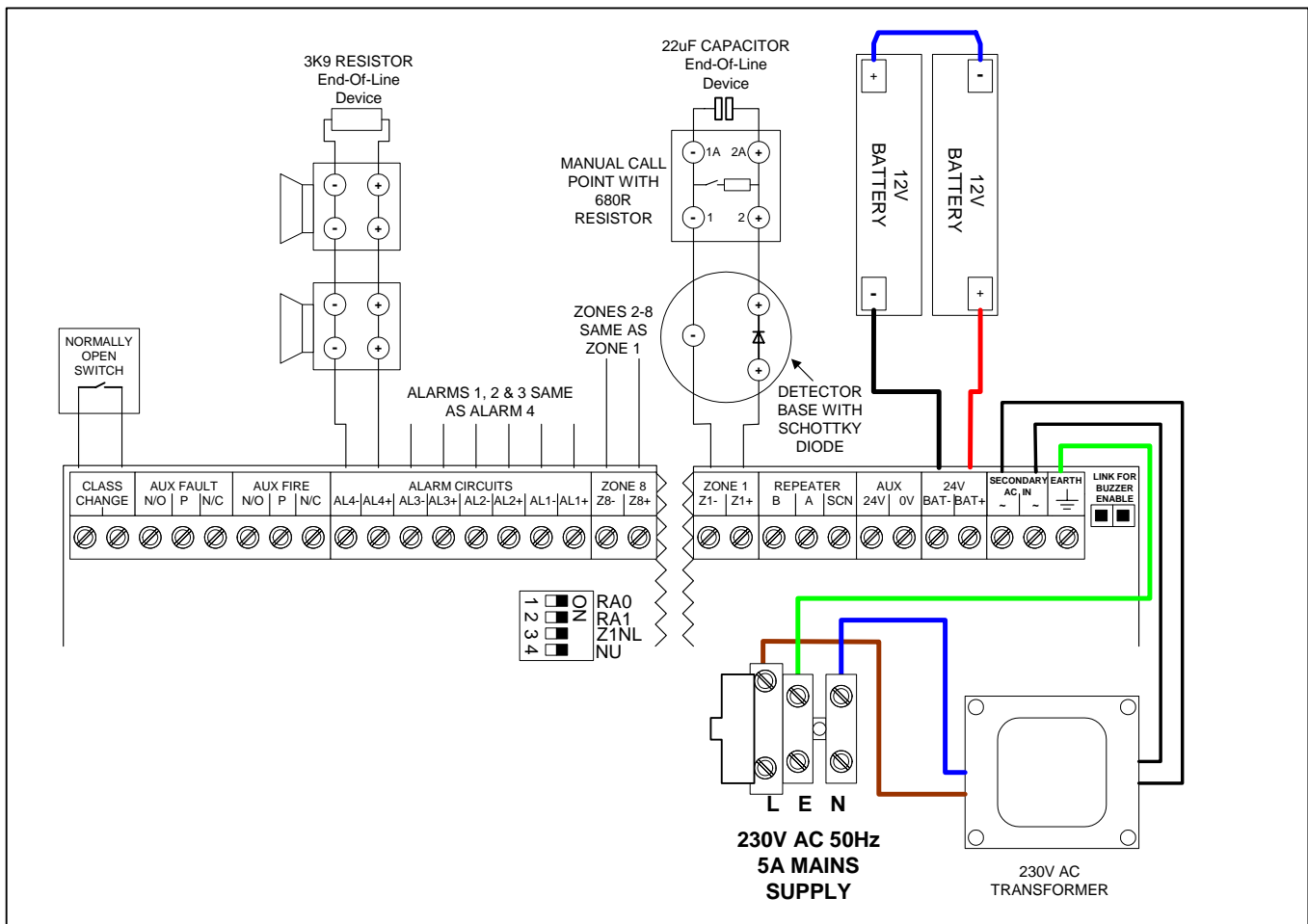

*Note: This is a schematic representation only and not a PCB layout drawing.*

### 4.2 Typical Repeater Wiring Schematic

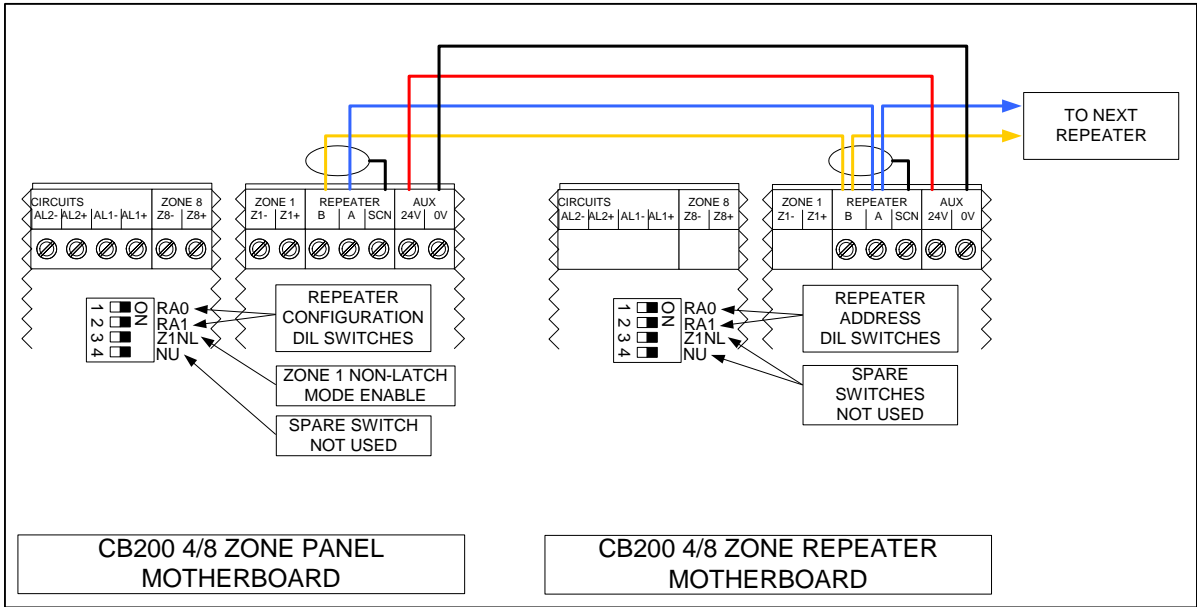

### 5. CB200 Panel Enhancements

The CB200 panel may be enhanced to provide additional facilities. The following table lists compatible panel enhancement products. Other relevant documentation is available providing more details.

#### 5.1 Panel Enhancement Order Codes & Descriptions

Part No	Description
2500/032	C1437 4 way alarm extender board - separate PSU required
2500/034	A1466 1 x double pole relay board (1A contacts)
2500/233	Heavy duty relay boxed (suppressed) – additional power supply required (2500/197 or 2500/198 as appropriate)
2500/220	Enclosure c/w 1A PSU & space for 4 x C1437 <b>and</b> 2 x A1466 & 6.2AH battery set Cabinet size - 380h x 600w x 210d
2500/221	Enclosure c/w 3A PSU & space for 2 x C1324 <b>or</b> 4 x C1437 boards Cabinet size - 380h x 600w x 210d
2500/222	Enclosure c/w 5A PSU & space for 2 x C1324 <b>or</b> 4 x C1437 boards Cabinet size - 380h x 600w x 210d

#### 5.2 Battery Sizes (YUASA)

The CB200 panel has been designed to house the 2.1AH battery set. The following batteries are suitable for any relevant expansion items, along with auxiliary power supplies, and should be selected accordingly.

Battery Rating	Battery Size
3.2AH battery 12V	134 length x 67 wide x 64 high
6.2AH battery 12V	151 length x 65 wide x 97.5 high
12AH battery 12V	151 length x 98 wide x 97.5 high
15AH battery 12V	181 length x 98 wide x 167 high

## **6. CB200 Panel Compatible Zone Devices**

The CB200 panel is designed to operate with the following devices. Detectors marked \* have been tested for compatibility. The remainder have electrical characteristics that are similar enough to the tested units to be listed as compatible.

Manufacturer	Part no.	Description	Maximum Quantity Per Zone
Apollo	53541-151	Series 30 ionisation detector	32 *
Apollo	53551-201	Series 20 optical detector	32 *
Apollo	53531-221	Series 30 Grade 1 heat detector	32
Apollo	45681-007	Series 20/30 mounting base	32 *
Apollo	55000-200	Series 60 ionisation detector	32 *
Apollo	55000-210	Series 60 integrating ion detector	32
Apollo	55000-100	Series 60 Grade 1 heat detector	32
Apollo	55000-101	Series 60 Grade 2 heat detector	32
Apollo	55000-102	Series 60 Grade 3 heat detector	32
Apollo	55000-103	Series 60 Range 1 heat detector	32
Apollo	55000-104	Series 60 Range 2 heat detector	32
Apollo	55000-300	Series 60 optical detector	32 *
Apollo	55000-380	Series 60 optical/heat detector	32
Apollo	45681-200	Series 60 mounting base	32 *
Hochiki	SLK-E	CD Range optical detector	32 *
Hochiki	SIH-E	CD Range ionisation detector	32 *
Hochiki	DFE-60E	CD Range 60 heat detector	32
Hochiki	DFE-90E	CD Range 90 heat detector	32
Hochiki	DCC-1EL	CD Range Grade 1 heat detector	32
Hochiki	DCC-2EL	CD Range Grade 2 heat detector	32
Hochiki	DCC-1REL	CD Range R1 heat detector	32
Hochiki	YBK-RL/4H1	CD Range mounting base	32 *
Hochiki	SLR-AS	CDX Range optical detector	32 *
Hochiki	SIJ-E	CDX Range ionisation detector	32
Hochiki	DFJ-60E	CDX Range 60 heat detector	32
Hochiki	DFJ-90E	CDX Range 90 heat detector	32
Hochiki	DCD-R1E	CDX Range Grade 1 heat detector	32
Hochiki	DCD-1E	CDX Range Grade 2 heat detector	32
Hochiki	DCD-2E	CDX Range R1 heat detector	32
Hochiki	YBN-R/4SK	CDX Range mounting base	32 *
Honeywell	TC804E-1022	Optical detector	32 *
Honeywell	TC805E-1005	Ionisation detector	32 *
Honeywell	TC830-1004	Heat detector	32
Honeywell	14506587-005	Mounting base (Diode version)	32 *
Nittan	80000	Sensortec ST-I ionisation detector	32
Nittan	80100	Sensortec ST-P optical detector	32
Nittan	82012	Sensortec STB-4SDR base	32
System Sensor	1151E	Ionisation detector	32 *
System Sensor	2151E	Optical detector	32 *
System Sensor	5451E	Grade 1 heat detector	32
System Sensor	4451E	Range 1 heat detector	32
System Sensor	1451E	Ionisation detector	32 *
System Sensor	2451E	Optical detector	32 *
System Sensor	B401RSD	Mounting base	32 *

Manufacturer	Part no.	Description	Maximum Quantity Per Zone
Ziton	Z630-1	Optical detector	32 *
Ziton	Z610-1	Ionisation detector	32 *
Ziton	Z6BS2A	Mounting base	32 *
KAC	KR9-680	Manual call point	Unlimited

## 6.1 Notes

1. When using Hochiki smoke detectors (types SIHE and SLKE) fit a 3K9 0.25 watt resistor across terminals L1 and S4.
2. When using Nittan detectors with RB3R bases fit a 220 ohm resistor across L and S1.
3. All call points must have a resistor in the range 470 Ohm to 680 Ohm fitted to them.

## 6.2 Other Compatible Zone Devices Order Codes & Descriptions

Part No	Description
2501/012	Break glass unit without back box c/w 680 ohm resistor
2501/013	Break glass unit with back box c/w 680 ohm resistor
2500/226	Remote square indicator
2500/227	Remote round indicator
2501/014	Spare glasses for break glass units (pack of 5)

## 6.3 General Accessories Order Codes & Descriptions

Part No	Description
2501/032	2.1AH S.L.A. battery set (2 x 12V)
2501/040	150mm bell (24 volts DC)
2501/044	Roshni Electronic Sounder (24 volts DC)
2501/043	Xenon flashing beacon (24 volts DC - 2 watts)
2501/033	Door retainer (24 volts DC) - auxiliary power supply required
2501/034	Door retainer (230 volts AC)
2501/035	Door retainer floor bracket
2500/198	1A 24V DC door retainer power supply unit in enclosure (no battery back-up) Size - 300h x 350w x 75d
2500/197	MPC1 1A power supply unit in enclosure with space for 3.2AH battery set Size 300h x 350w x 75d
2500/199	MPC3 3A PSU in enclosure with space for 12AH battery set Size 355h x 370w x 90d
2500/200	MPC5 5A PSU in enclosure with space for 24AH battery set Size 300h x 360w x 190d
2500/201	MPC10 10A PSU in enclosure with space for 24AH battery set Size 500h x 500w x 210d

## 7. Additional Available Documentation

Sales Literature  
 Installation & Commissioning Manual  
 User Instructions  
 Wiring Recommendations

Written by: R Patel

Checked by: **AJC**

After-Sales Technical Support Booklet